

HC-EX38

Flow sharing compensated valve

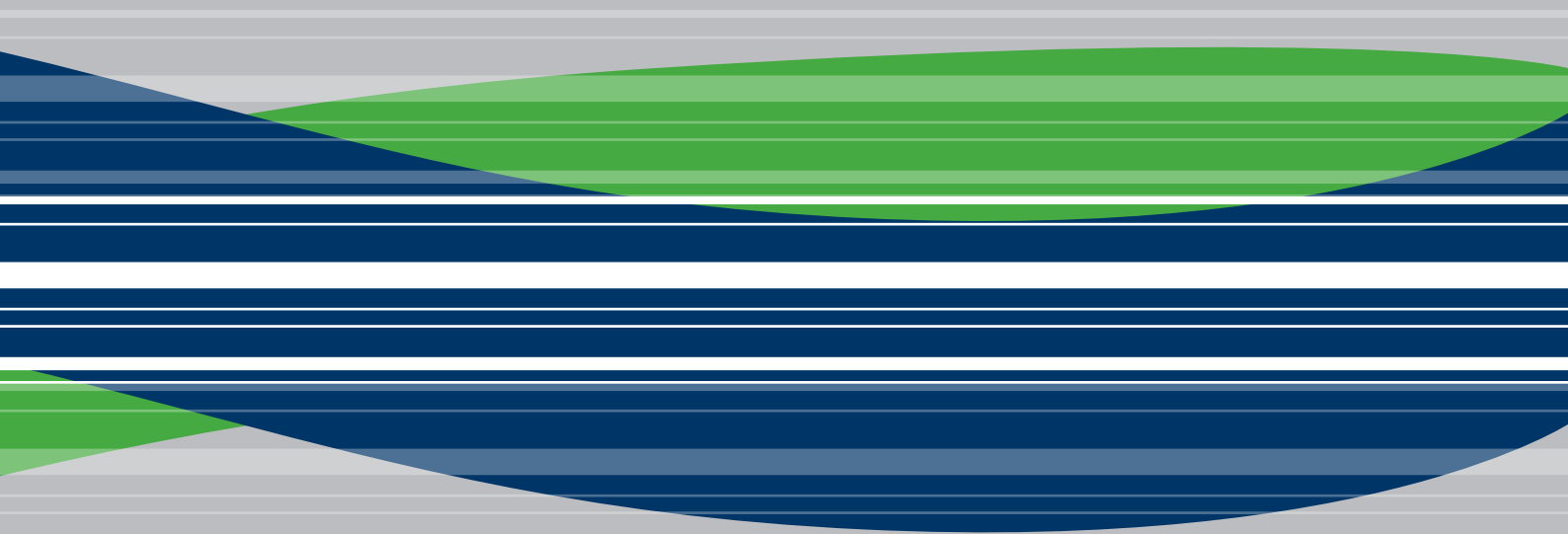

A global partner for innovative solutions

Functional advantages offered by the EX Family

PATENTED SYSTEM

All the control valves belonging to the EX family work according to a principle designed by Hydrocontrol's R&D department and covered by patents **EP1860327 (A1)** **EP1860327 (B1)** **US2008282691 (A1)** and **US7581487 (B2)**.

The valve LS signal is managed according to innovative technique which is an absolute first in the flow sharing world, ensuring:

- elimination of any LS signal bleed off, which can be observed in most systems currently available commercially, and is often the cause of poor compensation accuracy, slow response and excessive sensitivity to operating conditions.
- LS signal picking downstream of the local compensator: this will make signal detection "neater" improving control efficiency and accuracy.

RESPONSE RATE

The EX control valve's strength resides in its quick, prompt response, achieved thanks to the functional advantages built into our patented system. Even the most critical applications such as excavator bucket shacking and the swift dynamics of forestry machinery, usually hard to achieve on flow sharing systems, can be successfully implemented by using EX family products.

ACCURACY AND STABILITY

The unique technical characteristics of the Hydrocontrol's patent allows for outstanding flow control and compensation precision, not likely to be affected even by the most diverse operating conditions. Simultaneous functions are never mutually influenced, not even in the presence of the same load factors (an aspect best highlighted in crawler machinery travelling). System stability itself is greatly benefited by the EX design; the system, also in combination with traditional overcenter valves, appears well balanced and able to effectively reduce oscillation and dynamic instability.

EFFICIENCY

In addition to the well known advantages typically offered by flow sharing systems which, associated with a variable pump, will drastically reduce the machine operating consumption, the EX family introduces a number of interesting options, including pressure relief on the LS signal to further increase energy saving and guarantee top efficiency levels.

FLEXIBILITY

The EX family control valves can be easily adjusted to a variety of applications, thanks to the wide range of available options and different types of available control systems.

COMPACT DIMENSIONS

The carefully designed features and integrated electrohydraulic control ensure a highly compact and optimised layout. Integrated end plates are available in the final working section, adding to the system dimensional and functional efficiency.

PRIORITY

The EX family allow to install side by side pre-compensated section with post-compensated section. This feature allow to establish a priority in the way the oil is directed and increase the number of application where the EX family can be applied solving technical difficulties that before required external components. Both Inlets and Outlets remain common for the pre and post compensated sections making the assembling of the valve particularly convenient.



GENERAL SPECIFICATIONS	EX34	EX38	EX46	EX54	EX72
Working section number	1 - 10	1 - 10	1 - 10	1 - 10	1 - 8
CIRCUIT					
Spool stroke (mm)	7	7	8	9	11
Spool pitch (mm)	34	38	46	54	72
RATED FLOW					
Pump flow rate (l/min)	130	150	220	300	450
A/B port flow rate (l/min) (*)	80	100	180	250	350
RATED PRESSURE					
working pressure inlet port P (bar)	350	350	350	350	350
BACK PRESSURE MAX					
Max pressure outlet port T (bar)	10	10	10	10	10

(*) with fixed Pump inlet compensator

OPTION CHART	EX34	EX38	EX46	EX54	EX72
LS Signal pressure relief valve	•	•	•	•	•
Pump pressure relief valve	•	•	•	•	•
LS Signal dump valve (electric 12/24 Vdc)	•	•	•	•	•
Pump dump valve (electric 12/24 Vdc)	•	•	•	•	
SPOOLS TYPE					
Single acting	•	•	•	•	•
Double acting	•	•	•	•	•
Float spool	•	•	•	•	•
SPOOL ACTUATION					
Hydraulic actuation	•	•	•	•	•
Lever actuation	•	•	•	•	
Without lever	•	•	•	•	•
Cloche control		•	•		
Prop. electrohydraulic actuation 12-24 Vdc (*)	•	•	•	•	•
ON/OFF electrohydraulic actuation 12-24 Vdc (*)	•	•	•	•	•
CAN BUS interface actuation				on development	•
SPOOL RETURN ACTION					
Return spring	•	•	•	•	•
Mechanical detent	•	•	•	(•)	(•)
Hydraulic load limit	(•)	(•)	(•)		
Pneumatic control	(•)	(•)	(•)		
Spools displacement sensor (HLPS)	•	•	•	•	•
PORT RELIEF VALVE					
Antishock valve				•	•
Anticavitation valve	•	•	•	•	•
Antishock and anticavitation valve	•	•	•	•	•
Plug	•	•	•	•	•

• = available

(•) = special arrangement available on request

(*) = we recommend to keep the T line for the electrohydraulic cartridges separate from the T line of the valve.

GENERAL INDEX

4	General specifications Standard working conditions Fluid options Applications Operating principle
6	Pre and post compensated solutions Hydraulic schema - Post Compensated system Hydraulic schema - Pre Compensated system
7	Order example Standard thread Tie-rod kit classification Lever kit identification Painting
9	Dimensions HC-EX38 with manual control HC-EX38 with electrohydraulic control
11	Typical curves
15	Inlet Section Order example Inlet side classification Valve identification Valve arrangement Inlet classification
19	Working section Order example Spool identification Spool flow Spool actuation classification for manual control Spool return action classification for manual control Spool actuation classification for hydraulic control Spool actuation classification for electrohydraulic control Spool return action with hall effect linear position sensor Work section arrangement Auxiliary valves identification
31	Outlet section (end plate) Order example End plate for manual and hydraulic control End plate for electrohydraulic control Parallel connection of several valves High pressure carry over function
34	HC-EX38 Spare parts list Gasket kits Trasformation kits
38	Installation and maintenance Guidelines General clamping torque Dimensions - Thread codes Dimensions - SAE Flange codes
41	General conditions and patents Product identification

The specifications detailed in this catalogue show standard products. Special applications are available to order subject to contacting our Engineering Department for an estimate. The data and specifications indicated are to be considered a guide only and Hydrocontrol S.p.A. reserves the right to introduce improvements and modifications without prior notice. Hydrocontrol is not responsible for any damage caused by an incorrect use of the product.

GENERAL SPECIFICATION

Standard working conditions

Ambient operating temperature range	-40°C / +60°C
Kinematic viscosity range	10 ÷ 300 cSt
Max contamination level	9 (NAS 1638) - 20/18/15 (ISO 4406:1999)
Recommended filtration level	β10 > 75 (ISO 16889:2008)
Internal filter (on electroproportional valves pilot line)	30 μm

All information and diagrams in this catalogue refer to a mineral base oil VG46 at 50°C temperature (32 cSt kinematic viscosity)

Fluid options

Types of fluid (according to ISO 6743/4) Oil and Solutions	Temperature (°C)		Compatible gasket
	min	max	
Mineral Oil HL, HM (or HLP acc. to DIN 51524)	-25	+80	NBR
Oil in water emulsions HFA	+5	+55	NBR
Water in oil emulsions HFB	+5	+55	NBR
Polyglycol-based aqueous solution HFC	-10	+60	NBR

For special applications and different fluids, please call our Technical Department.

Applications

Flow Sharing valve for 150 l/min inlet flow rate: suitable for applications including truck-mounted cranes up to 25 tm, forestry creanes, tractors and mini-excavators up to 6 t.



Operating principle

The flow sharing technology applied to the standard load sensing system characterizes the new control valves HC-EX. The valve, completely pressure compensated, guarantees great controllability to all actuations, making workport flow dependent only on metering area (spool position). When flow saturation occurs the system reacts by implementing an equal reduction of pressure margin across all spools, generating a proportional reduction of workport flow.

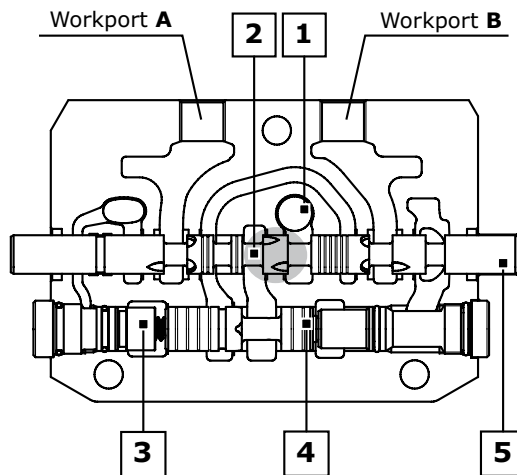

LEGEND:

1. Inlet line (High pressure)
2. Metering notches
3. Load sensing line
4. Local compensator
5. Metering spool

Single section

Referring to picture it's possible to remark some aspects of system functionality. Coming from the common inlet line the main flow, passing across the metering area, reaches local compensator. Metering area, according to the pressure margin, controls the total amount of flow to the workport selected by the main spool. The load sensing signal, picked up downstream the local compensator, feeds the common load-sensing line. When a single section is actuated, the local compensator fully opens to the left side, reaching its complete balanced position. The control of the LS system is made by the inlet compensator for fixed displacement pump or pump compensator for variable displacement pump.

Multi-section

When two or more sections are actuated only one, characterized by the highest pressure (dominant), is involved in the LS signal transmission, working as briefly described in the previous paragraph. The other functions (slaves) become directly dependent on it. The common LS line transfers the information coming from the dominant local compensator to all dependent compensators. Driven by the LS signal, the unbalanced slave compensators activate the pressure compensation creating an artificial pressure drop able to keep pressure margin nominally the same on all the spools. Workport flow becomes only a function of metering area making the system totally load independent.

Flow Sharing function

When saturation occurs the total amount of flow required by actuations is higher than the maximum pump flow rate. The system is able to keep the nominal pressure margin no more. The actual pressure margin reduces according to real flow demand. Since all the local compensators feel the same LS signal and the same pressure drop is applied to different metering areas, then workport flows are reduced proportionally in order to keep all actuations completely under control.

PRE AND POST COMPENSATED SOLUTIONS

HC-EX family offers a precious additional feature: the possibility to mix pre and post compensated technologies, to improve the control capabilities and manage flows with different priorities. Following schematics show an example for the two systems. Further detail are explained on page 26.

HYDRAULIC SCHEMA - Post compensated system

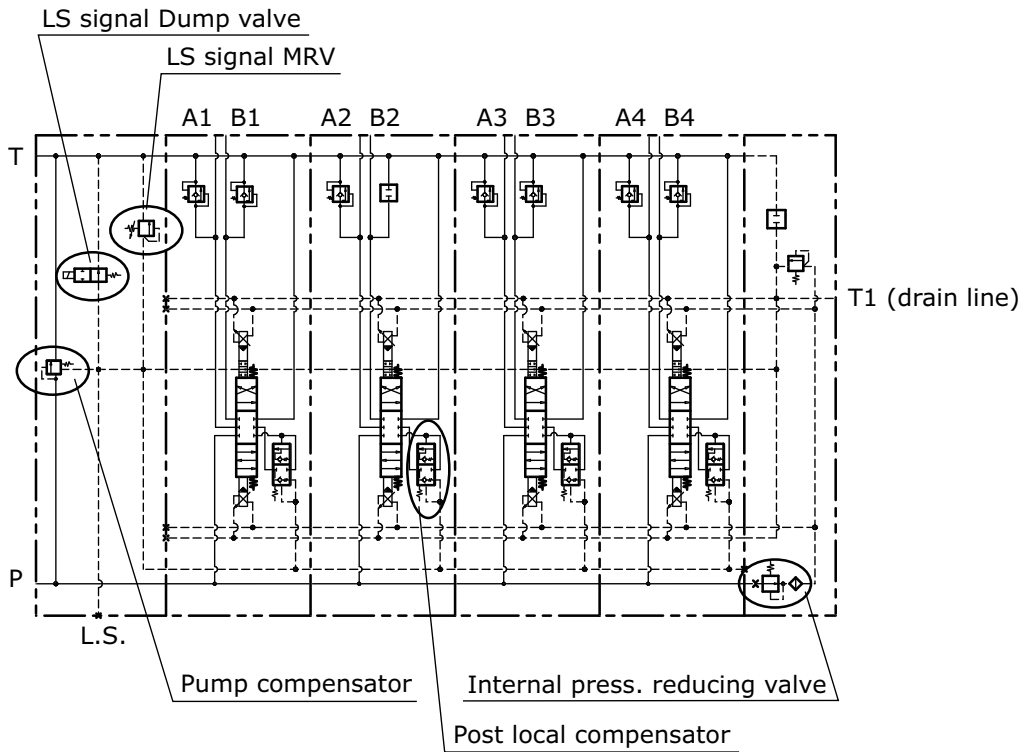

HYDRAULIC SCHEMA - Pre compensated system

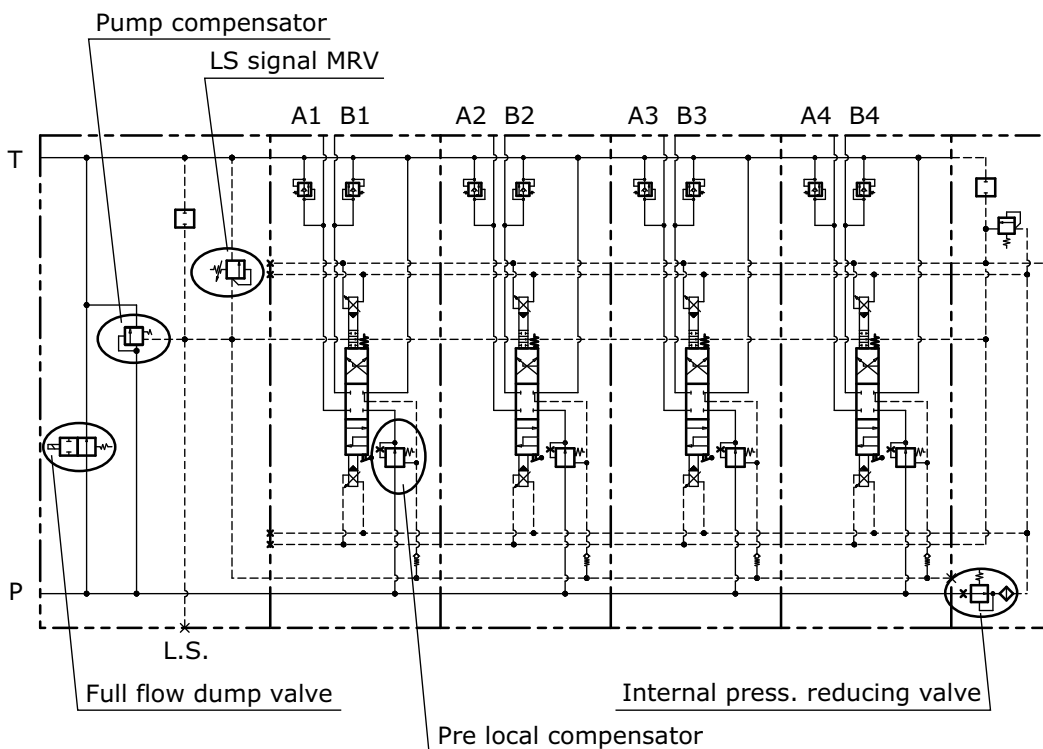

ORDER EXAMPLE

HC-EX38/1: MR 701 200 KV G05 - W001C 2525 H404 RC1 G04 03TF PA 100 03TF PB 150 - KZ20EH

TYPE: _____
EX38: product type
/1: working section number

- 1) INLET ARRANGEMENT:** _____
MR 701 inlet side and valve type
200 setting (bar)
KV G05 inlet position and available thread type

- 2) WORK SECTION ARRANGEMENT:** _____
W001C 2525 type and spool delivery
H404 spool actuation type
RC1 G04 section type and port threads
03TF PA 100 auxiliary valve (port A)
03TF PB 150 auxiliary valve (port B)

- 3) OUTLET ARRANGEMENT (END PLATE):** _____
KZ20EH plate type

Ordering row 2 must be repeated for every work section

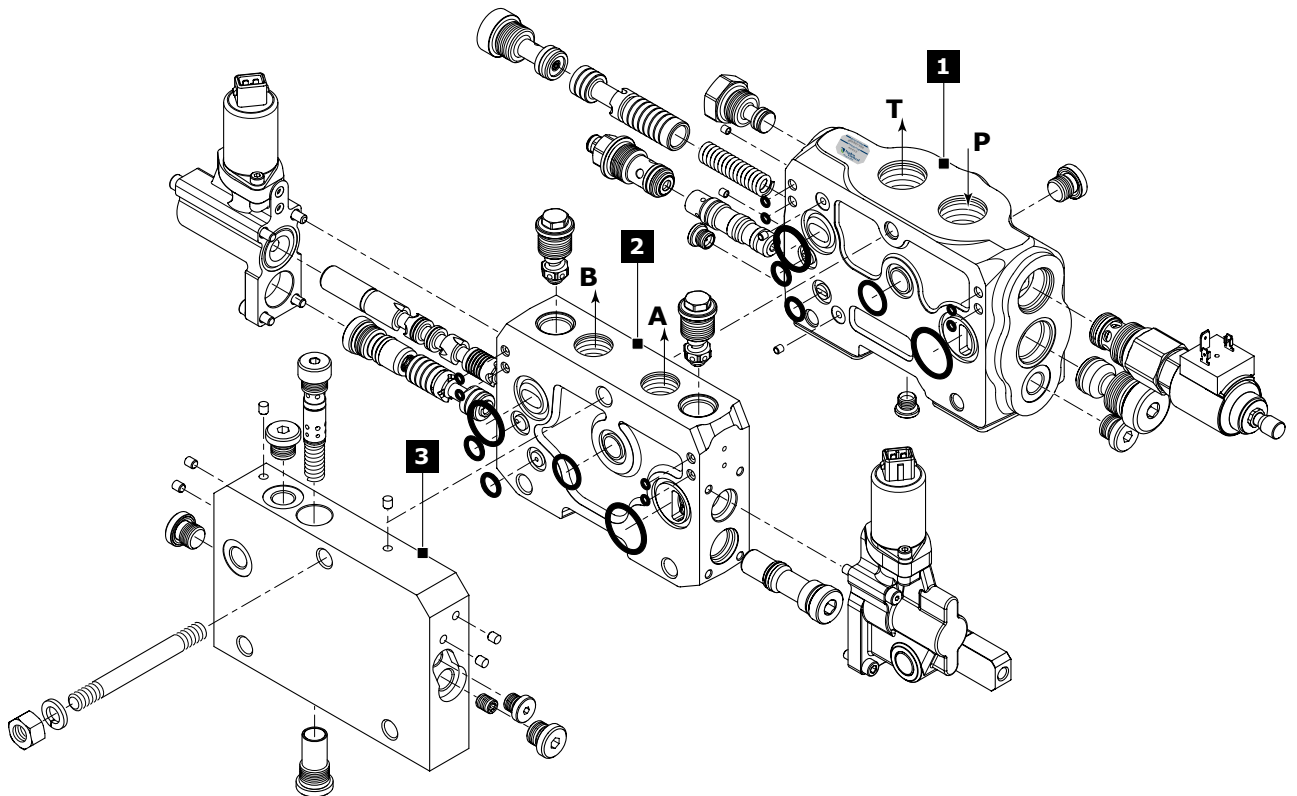

Standard thread

The connection ports size is indicated by an ordering code common for all Hydrocontrol products. Following table shows all available connections; for ordering code refer to table on page 40.

ports	BSP (ISO - 228)	UN-UNF (ISO - 725)
Ports (P - T)	G 3/4	1"1/16 - 12 UNF
Ports (A - B)	G 1/2	7/8" - 14 UNF

Tie-rod kit classification

Tie rod kit allows the correct assembly of sectional valves. Tie rod's length depends on the number of sections; each valve is assembled with tie rod kits including a tie rod, nut and washer.

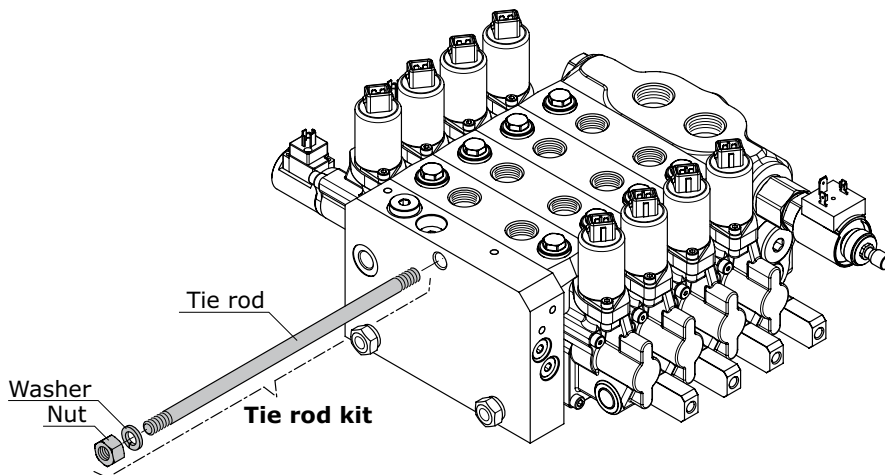

tie rod length	/1	/2	/3	/4	/5	/6	/7	/8	/9	/10
(mm)	95	133	172	210	248	287	324	361	400	438
Tie rod clamping torque	40 Nm									

Lever kit identification

Hydrocontrol can supply a lever kit to be assembled on the valve's manual controls; different lengths and threads are available. Lever kits must be ordered separately.

type	description	code
ZA - M8 - 135	Lever with knob (135 mm)	430503001
ZA - M8 - 210	Lever with knob (210 mm)	430503002

Order example:

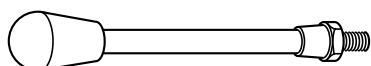

ZA - M8 - 210

- └─ Lever length (mm)
- └─ Lever thread
- └─ Lever type

Painting

On request, all Hydrocontrol valves can be delivered painted (RAL 9005 black primer).

Order example of EX38/1 painted:

HC-EX38/1
 MR 701 200 KV G05
 W001C 2525 H404 RC1 G04 03TF PA 100 03TF PB 150
 KZ20EH
P006/1 N10

The painting is indicated with the following value:

P006 - /1 - N10

- └─ Color black
- └─ section number
- └─ Painted

DIMENSIONS

HC-EX38 with manual control

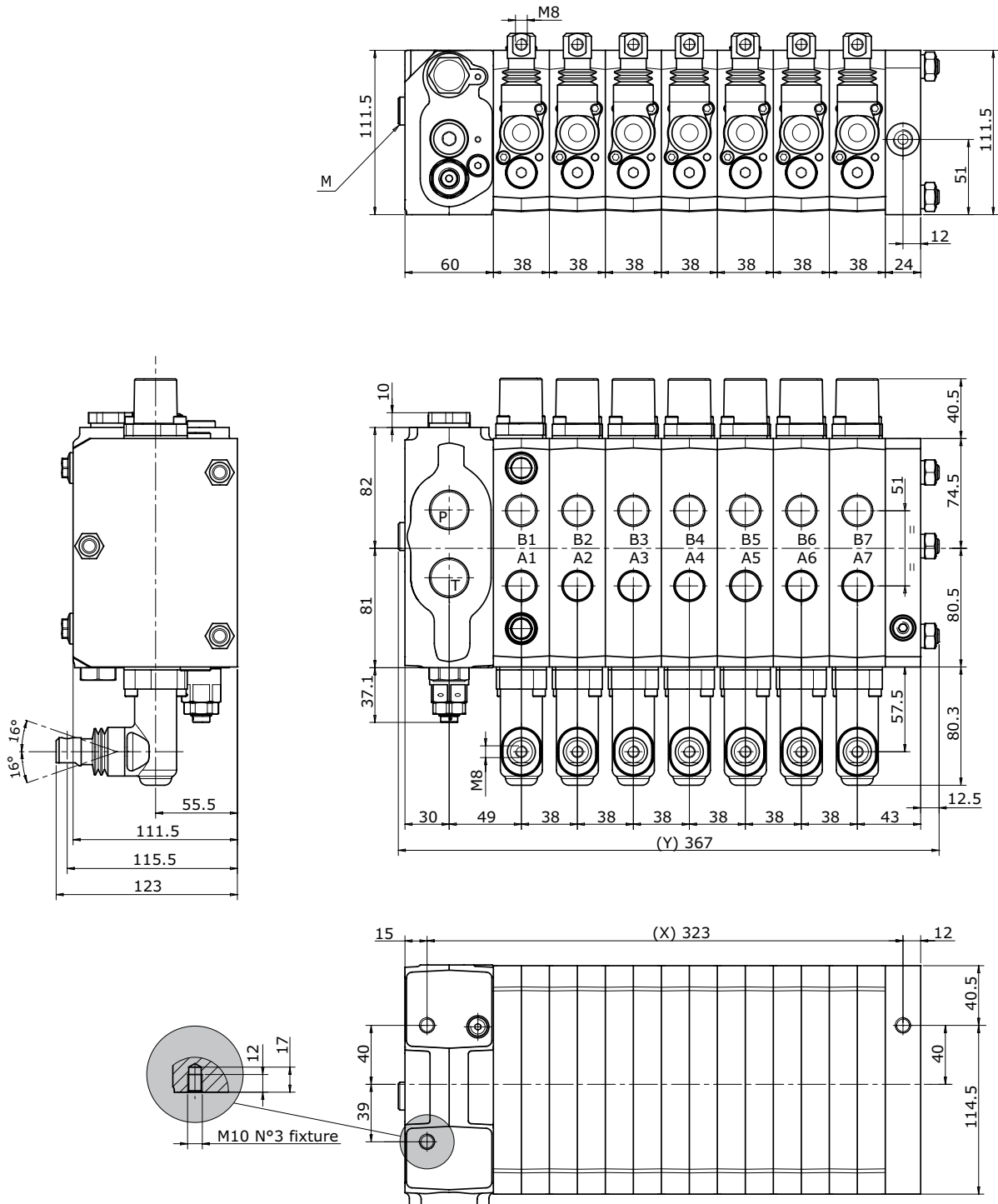

type	/1	/2	/3	/4	/5	/6	/7	/8	/9	/10
X (mm)	95	133	171	209	247	285	323	361	399	437
Y (mm)	139	177	215	253	291	329	367	405	443	481
Weights (kg)	14,5	18,5	22,5	26,5	30,5	34,5	38,5	42,5	46,6	50,5

DIMENSIONS

HC-EX38 with electrohydraulic control

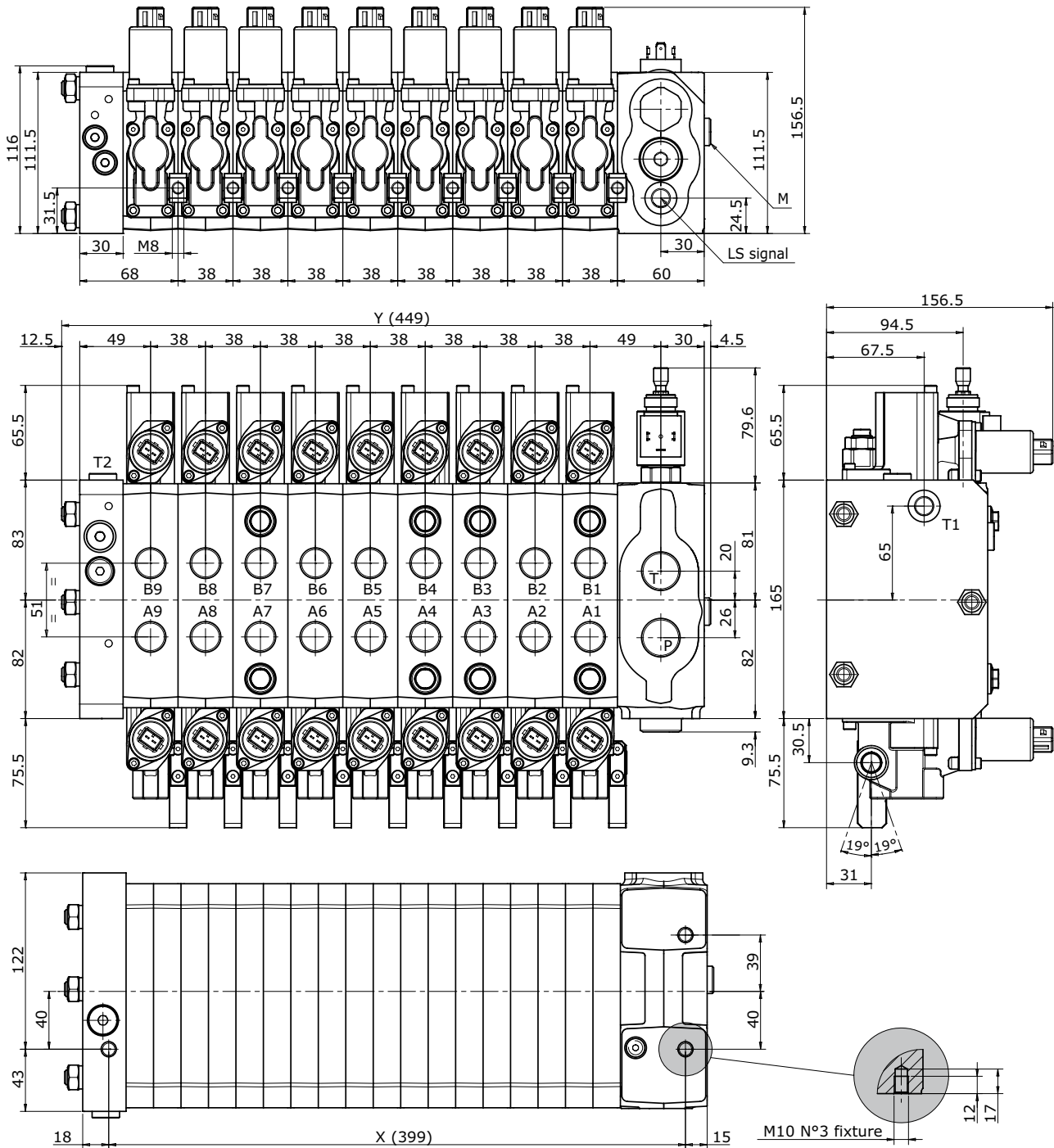

type	/1	/2	/3	/4	/5	/6	/7	/8	/9	/10
X (mm)	95	133	171	209	247	285	323	361	399	437
Y (mm)	145	183	221	259	297	335	373	411	449	487
Weights (kg)	15	19,5	24	28,5	33	37,5	42	46,5	51	55,5

TYPICAL CURVES

Inlet compensator Pressure drop (P-T)

Fixed displacement system (KV): pressure drop across the inlet compensator as function of pump flow

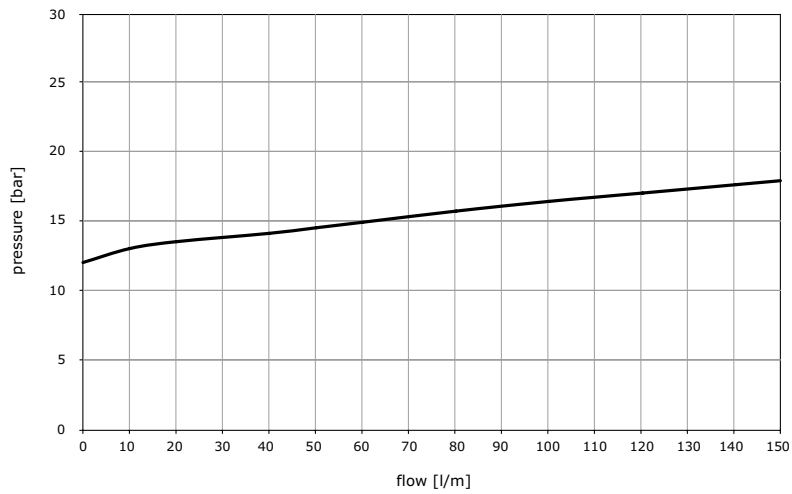

LS relief valve

Fixed displacement system (KV): LS relief valve characteristic

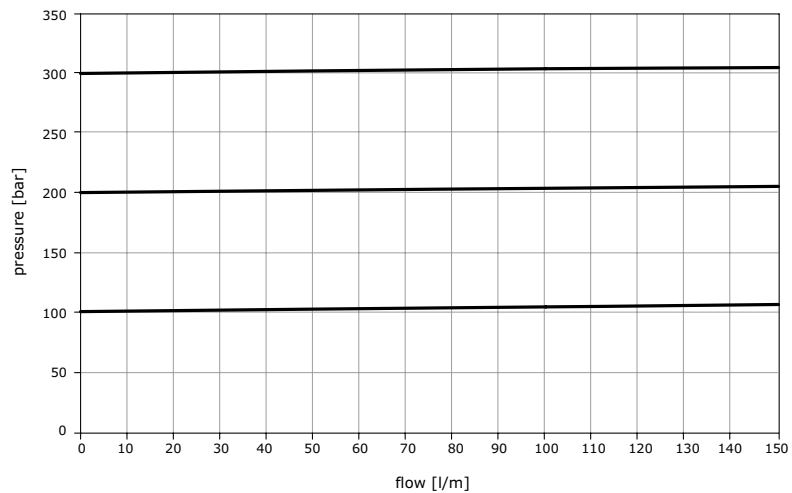

Full flow dump valve (valve type 7, 8)

Fixed displacement systems (KV): pressure drop across open electric dump valve as function of pump flow

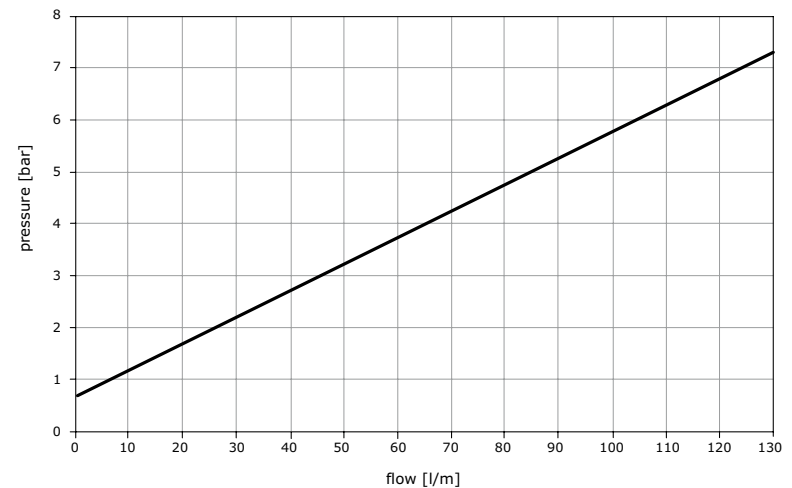

TYPICAL CURVES

Post compensated spool flow characteristic

Fixed displacement systems (KV): flow on ports A and B as function of spool stroke, pilot pressure, control current
 Inlet flow: 120 l/min

Pump inlet compensator at 14 bar Δp

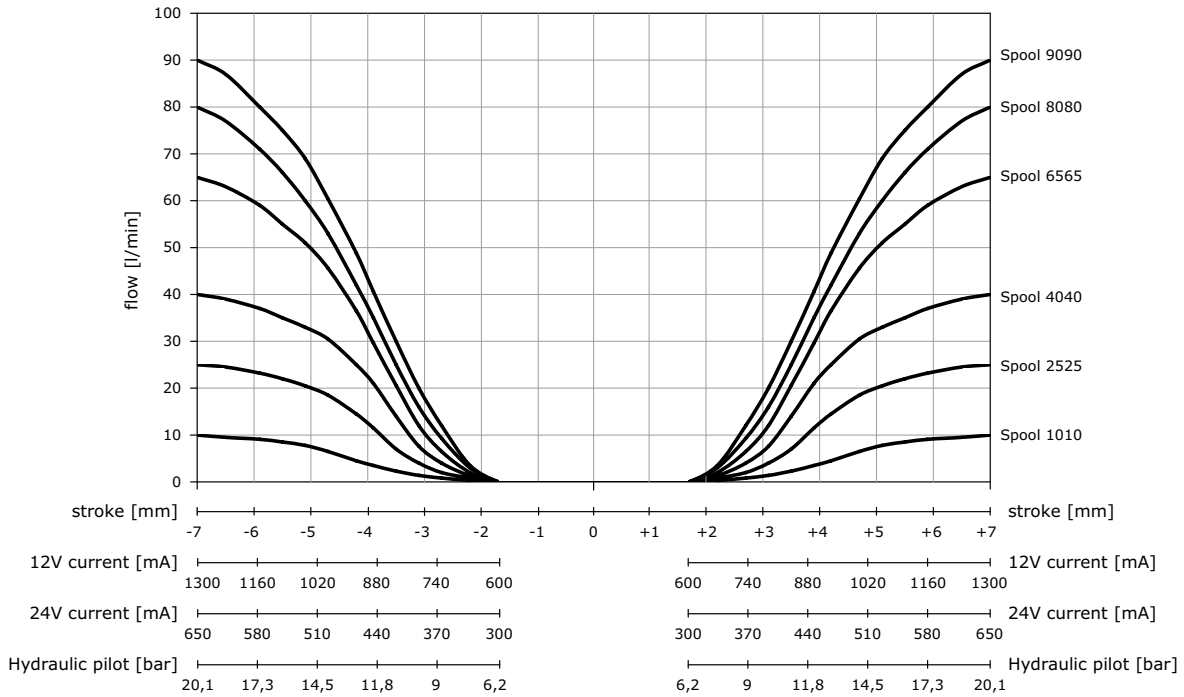

Post compensated spool flow with variable displacement pumps

Variable displacement systems (JV): spools maximum delivered flow as function of pump ΔP setting

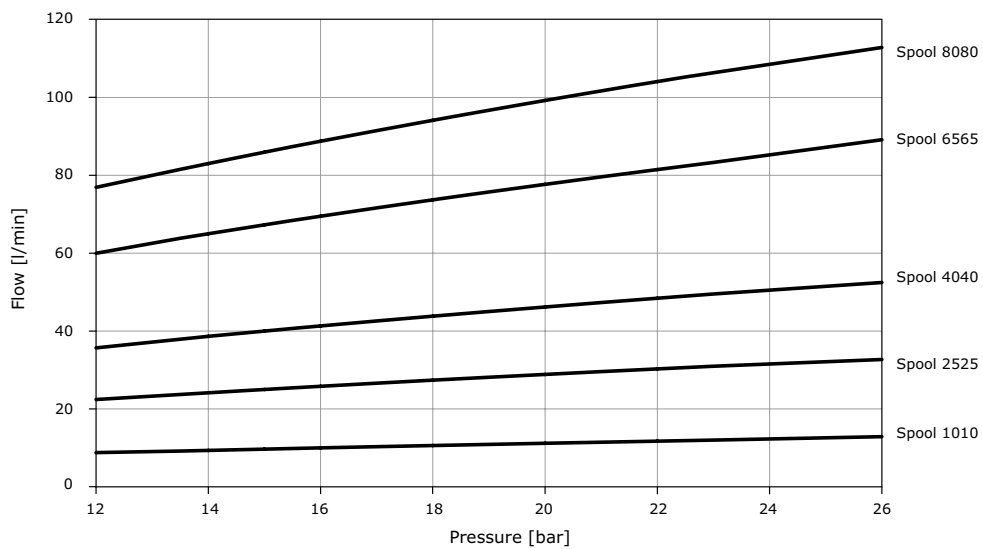

TYPICAL CURVES

Pre compensated spool flow characteristic

Fixed displacement systems (KV): flow on ports A and B as function of spool stroke, pilot pressure, control current
 Inlet flow: 120 l/min

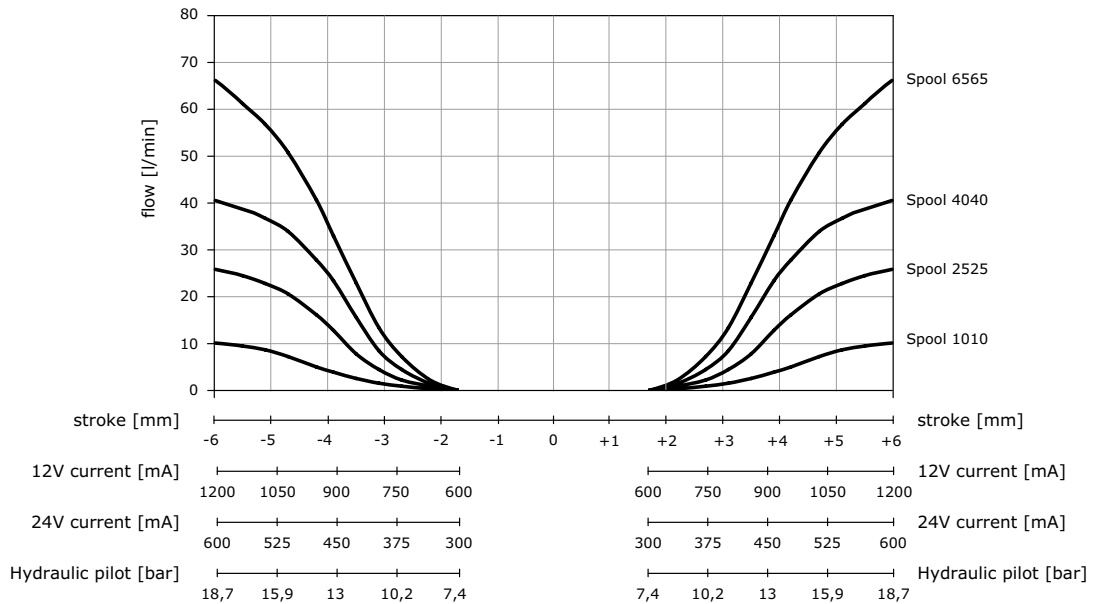

Post compensated float spool characteristic

Fixed displacement systems (KV): flow and float position as function of spool stroke, pilot pressure, control current
 Inlet flow: 120 l/min

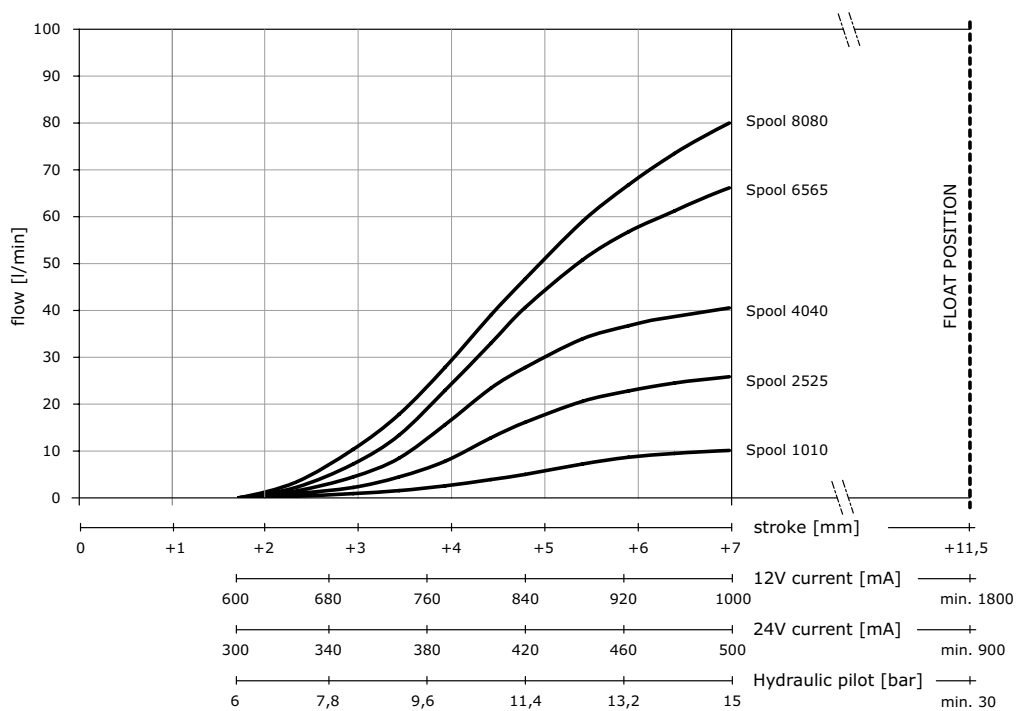

TYPICAL CURVES

Combined valves (antishock function)

Pressure characteristic as function of flow

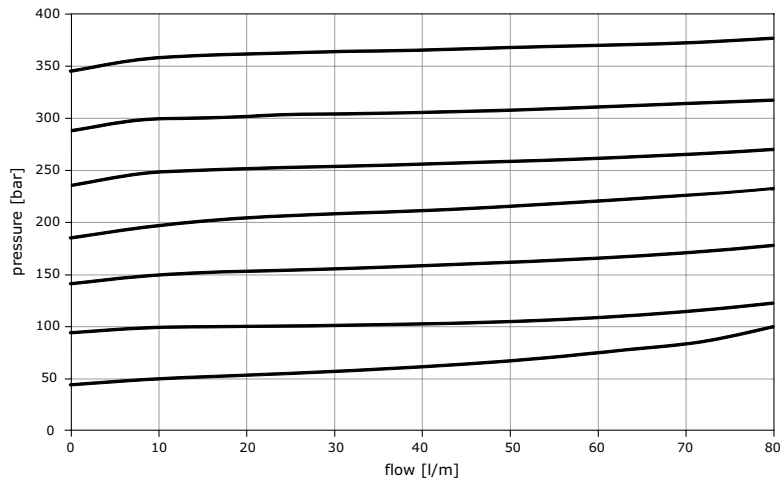

Combined valves (anticavitation function)

Opening and pressure characteristic as function of flow

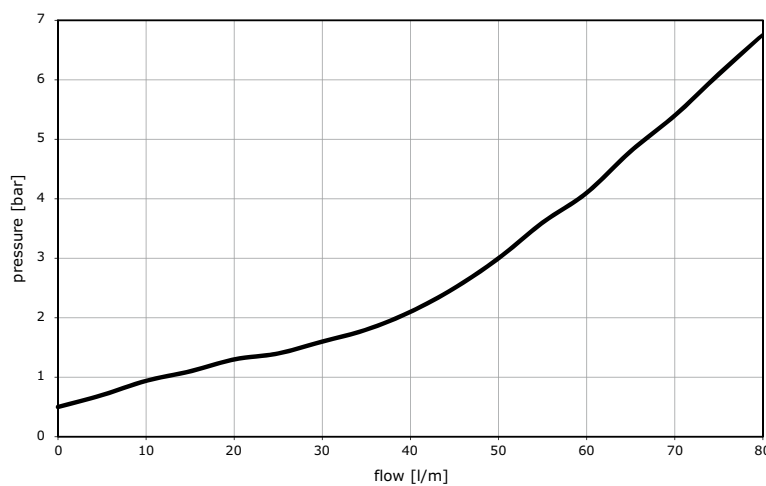

INLET SECTION

Order example

			MR 701 200 KV G05
	MR	inlet side	_____
1.	701	valve arrangement	_____
	200	setting (bar)	_____
2.	KV G05	inlet position and available thread type	_____

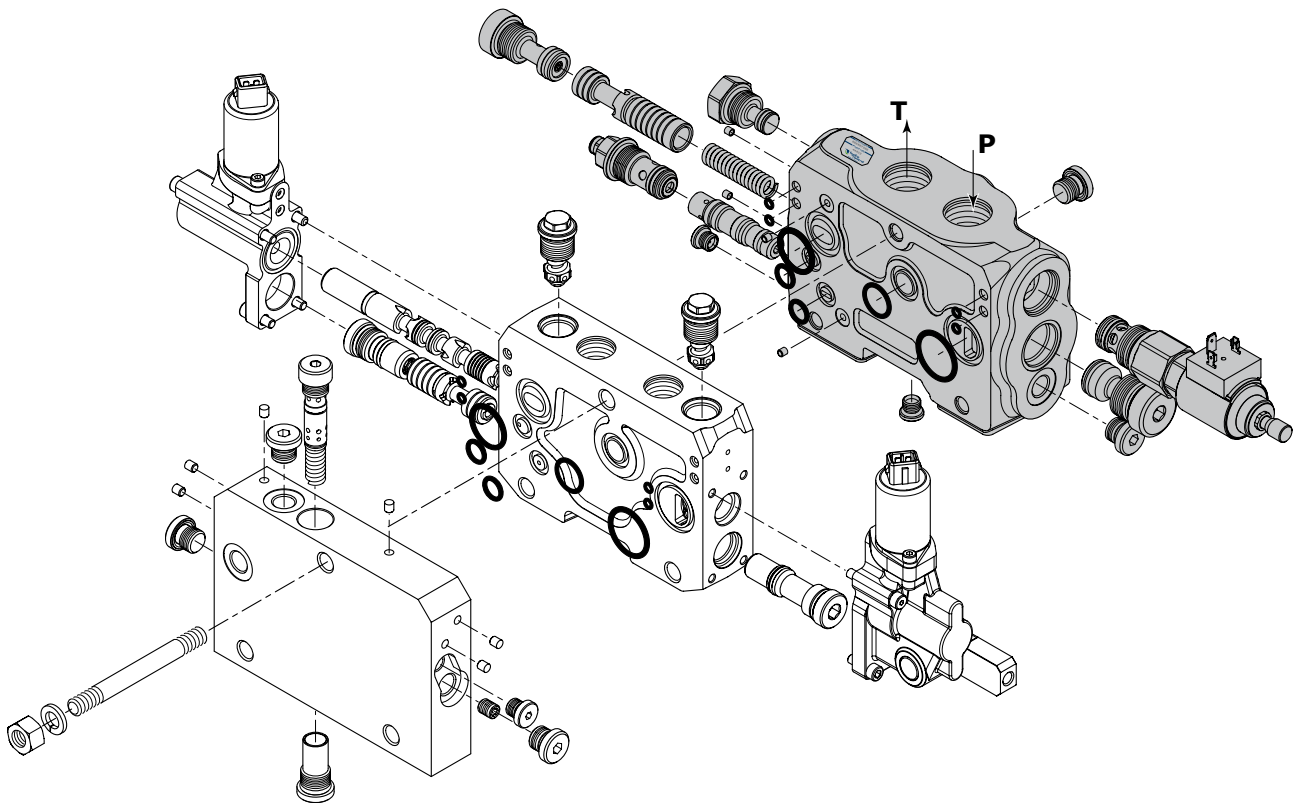
**INLET SIDE:**

pg. 16

MR	Flow sharing valve with right inlet section
ML	Flow sharing valve with left inlet section

1. VALVE ARRANGEMENT: (standard combinations)

pg. 17

700	Inlet section with LS pressure relief valve and full flow pilot operated pressure relief valve
701	Inlet section with LS pressure relief valve
702	Inlet section with LS pressure relief valve and LS electric dump valve 12 Vdc
703	Inlet section with LS pressure relief valve and LS electric dump valve 24 Vdc
704	Inlet section with LS pressure relief valve and full flow electric dump valve 12 Vdc
705	Inlet section with LS pressure relief valve and full flow electric dump valve 24 Vdc
706	Inlet section without valves

2. INLET CLASSIFICATION:

pg. 18

KV G05	Open centre inlet section for fixed displacement pumps (G 3/4)
JV G05	Closed centre inlet section for variable displacement pumps (G 3/4)
KV U05	Open centre inlet section for fixed displacement pumps (1"1/16 - 12 UN)
JV U05	Closed centre inlet section for variable displacement pumps (1"1/16 - 12 UN)

NOTE: when ordering a relief valve it is necessary to specify factory setting (example 200 bar).

Inlet side classification

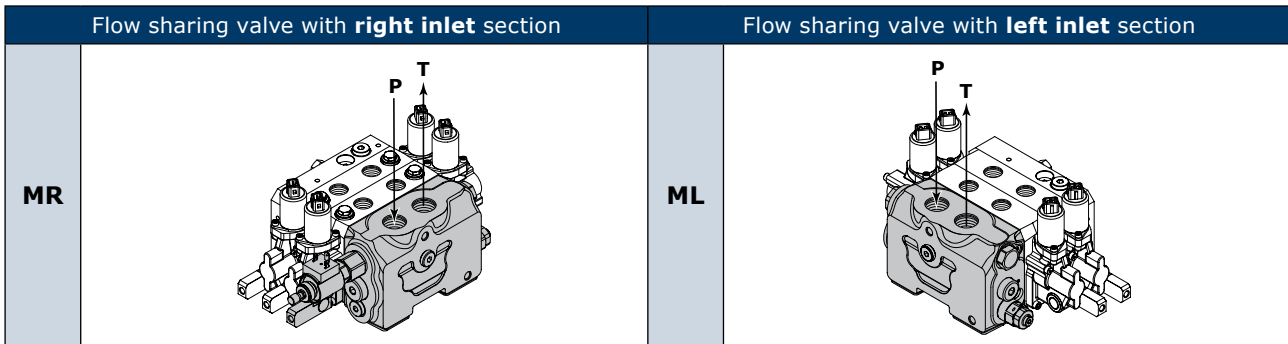

Valve identification

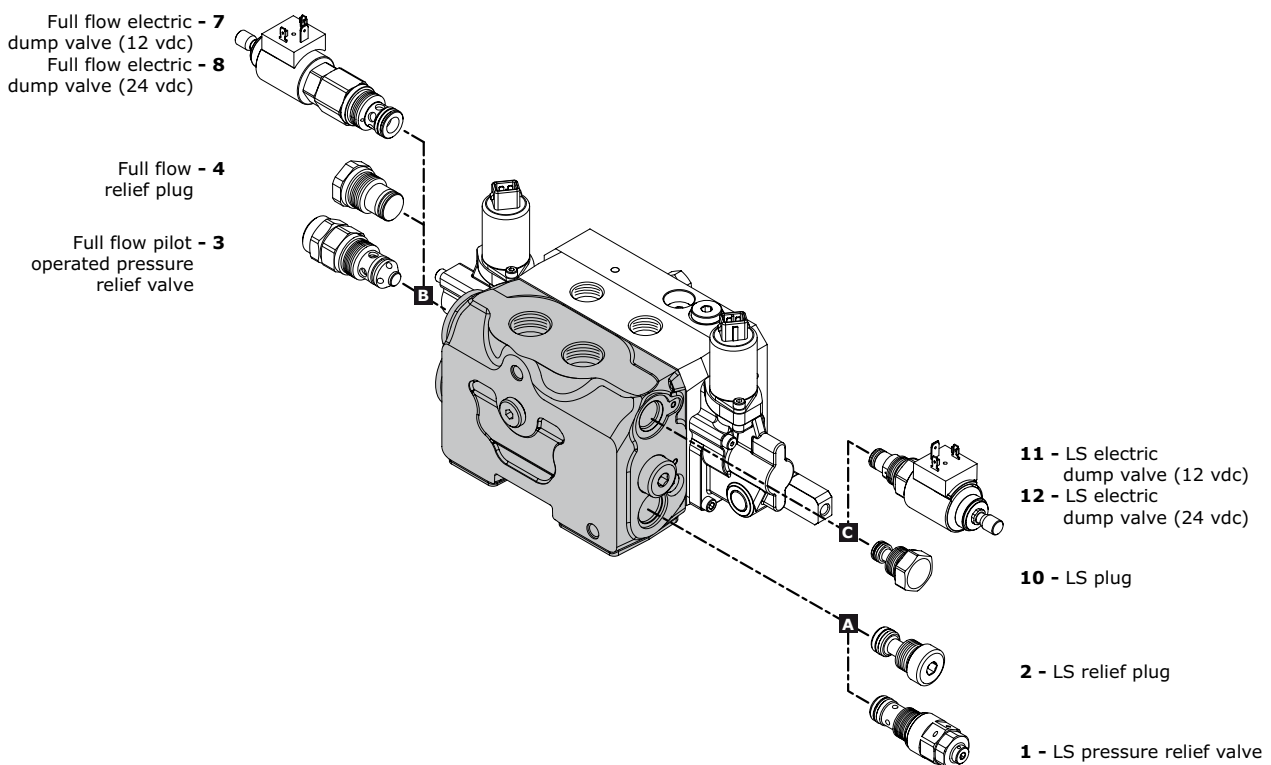

type	schema	layout	description	type	schema	layout	description
1			LS pressure relief valve	7			Full flow electric dump valve (12 vdc)
				8			Full flow electric dump valve (24 vdc)
2			LS relief plug	10			LS plug
3			Full flow pilot operated pressure relief valve	11			LS electric dump valve (12 vdc)
4			Full flow relief plug	12			LS electric dump valve (24 vdc)

Valve arrangement

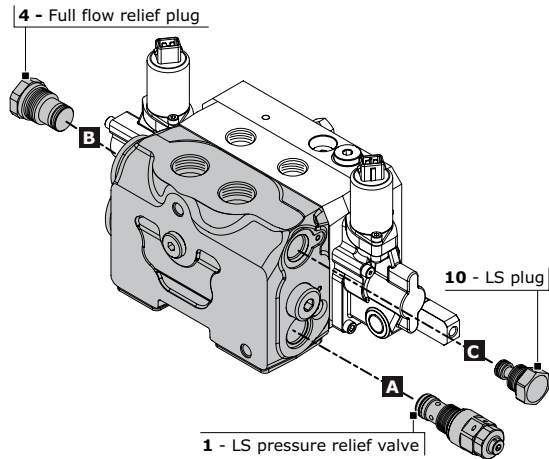

Valve combination example: 701 = 1A - 4B - 10C

- 701 Valve combination
- 1A LS pressure relief valve in port A
- 4B Full flow relief plug in port B
- 10C LS plug in port C

The code identifies:

with a number, the type of valve; with a letter its position on the inlet section.

NOTE: when ordering a combination type 701, 702, 703, 704 and 705 it is necessary to specify pressure setting.

VALVE COMBINATION INLET SECTION	Port - A			Port - B			Port - C		
	1	2	3	4	7	8	10	11	12
700	•		•				•		
701	•			•			•		
702	•			•				•	
703	•			•					•
704	•				•		•		
705	•					•	•		
706		•		•			•		
707		•		•				•	
708		•		•					•
709		•			•		•		
710		•				•	•		

NOTE: Valve combination 700 requires minimum 40 bar difference in setting of full flow and LS relief valves (see example).

MR 700 200*240 KV G05

- 700 valve combination
- 200 setting (bar); LS pressure relief valve
- 240 setting (bar); Full flow pilot operated pressure relief valve

Dump valve coil specifications

GENERAL AND TECHNICAL SPECIFICATIONS		
Ordering code	413171235	413172432
Supply voltage (Vdc)	12	24
Coil resistance R ₂₀ (Ω)	7	28
Connector	DIN 43650 / ISO 4400	
Connector material	Nylon	
Coil Body	Zinc plated steel	
ED 100%		
Class H coil as from IEC 85 standard		
Class H wire (200°C)		

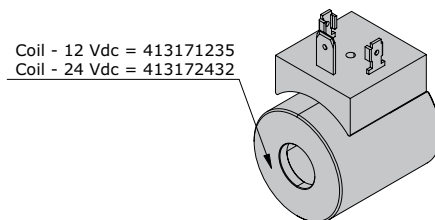

NOTE: mating connector for DIN 43650 can be ordered separately with code 413000313. Different connector available on request.

Inlet classification

Inlet combination and thread available			
KV G05			<p>Open centre inlet section</p> <p>for fixed displacement pumps</p>
KV U05			
<p>The inlet section with KV configuration enables control valve usage with fixed displacement pumps. With this configuration the presence of LS relief valve (valve type 1) is suitable to adjust the system maximum pressure. Full flow electric dump valve (valve type 7, 8) can also be added as safety device.</p>			
JV G05			<p>Closed centre inlet section</p> <p>for variable displacement pumps</p>
JV U05			
<p>The inlet section with JV configuration enables control valve usage with variable displacement pumps. With this configuration the presence of LS relief valve (valve type 1) is suitable to adjust the system maximum pressure. LS electric dump valve (valve type 11, 12) can also be added as safety device. An additional full flow relief valve (valve type 3) can be added to protect the system from pump regulator failures. Additional solution for variable displacement pumps is available on request to allow a constant reduced free flow in stand by condition through the system: this is sometime required to guarantee a stand by flow for oil cooling.</p>			

NOTE: transformation of the inlet section from closed center to open center and vice versa is possible by ordering the appropriate kit 320093007 or 320093008 (see page 37)

WORKING SECTION

Order example:

W001C 2525 H404 RC1 G04 03TF PA 100 03TF PB 150

- 1. **W001C** spool type _____
- 2525** spool flow _____
- 2. **H404** spool actuation type _____
- 4. **RC1** section type _____
- G04** thread type _____
- 5. **03TF PA 100** auxiliary valve type (port A - handle side) _____
- 6. **03TF PB 150** auxiliary valve type (port B - end cap side) _____

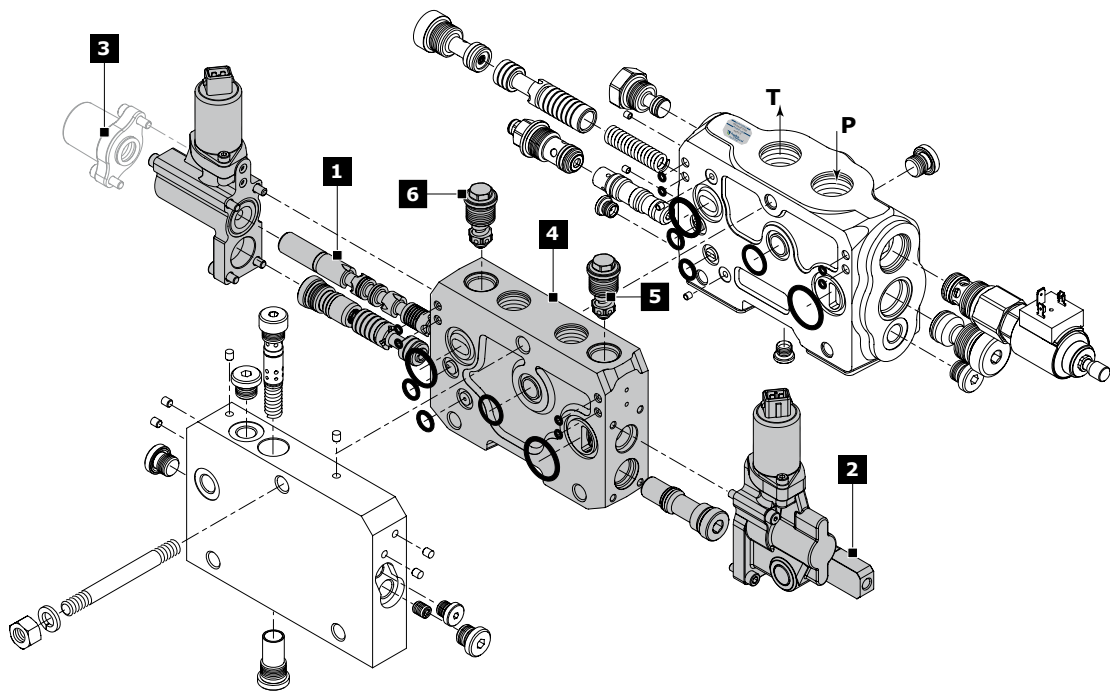

- 1. **SPOOL TYPE:** pg. 20
 - W001C** 3 positions double-acting
 - W002C** 3 positions double-acting partly open to tank
 - W012C** 4 positions double-acting with float in the 4th pos.

A 4 digit code identify the flow required on port A/B. These flows are available: 5-10-15-25-35-50-65-80-100 l/min
Example : W001C - 2525
- 2. **SPOOL ACTUATION TYPE:** pg. 21
 - H001** lever actuation
 - H005A** hydraulic actuation (pilot ports on the top)
 - H404** lever actuation + electrohydraulic actuation 12 vdc
 - H405** lever actuation + electrohydraulic actuation 24 vdc
- 3. **SPOOL RETURN ACTION TYPE (*):** pg. 22
 - F001A** 3 positions spring-centred spool (spring A)
 - F002A** Detent in A and B (spring A)

- 4. **SECTION TYPE** pg. 26
 - RC1 G04** Post-Compensated section arranged for auxiliary valve (G 1/2)
 - RC2 G04** Post-Compensated section not arranged for auxiliary valve (G 1/2)
 - RL1 G04** Pre-Compensated section arranged for auxiliary valves (G 1/2)
 - RL2 G04** Pre-Compensated section not arranged for auxiliary valve (G 1/2)
 - RC1 U04** Post-Compensated section arranged for auxiliary valve (7/8"-14 UN)
 - RC2 U04** Post-Compensated section not arranged for auxiliary valve (7/8"-14 UN)
 - RL1 U04** Pre-Compensated section arranged for auxiliary valve (7/8"-14 UN)
 - RL2 U04** Pre-Compensated section not arranged for auxiliary valve (7/8"-14 UN)
- 5. **AUXILIARY VALVE TYPE (PORT A)** pg. 30
 - 02TF PA** Fixed setting Anticavitation valve (port A)
 - 03TF PA** Fixed setting combined valve (port A)
 - 05TF PA** Fixed setting Prearrang. for aux. valve (port A)
- 6. **AUXILIARY VALVE TYPE (PORT B)** pg. 30
 - 02TF PB** Fixed setting Anticavitation valve (port B)
 - 03TF PB** Fixed setting combined valve (port B)
 - 05TF PB** Fixed setting Prearrang. for aux. valve (port B)

NOTE: (*) Leave out the spool return action code when choosing H403, H404, H405, H407, H408, H424, H425, H426, H427, H428, H429 and hydraulic actuation H005A, H005C and H005L.

Sections designed to house auxiliary valve option require double choice on work ports A and B.

Always indicate setting value when using fixed setting combined valve: **03TF PA (120) - 03TF PB (120)**

Spool identification

POST-COMPENSATED SECTION

W001C

3 positions double-acting

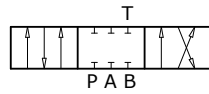

W002C

3 positions double-acting partly open to tank

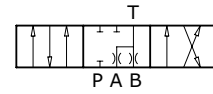

W012C

4 positions double-acting with float in the 4th position

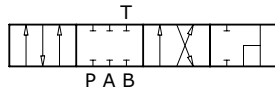

W102C

3 positions double-acting A and B to tank (motor spool)

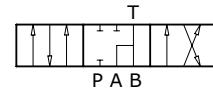

PRE-COMPENSATED SECTION

W001C

3 positions double-acting

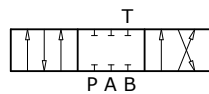

W002C

3 positions double-acting partly open to tank

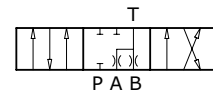

Spool flow

Flow rates delivered to the A and B ports are identified in following table. Rated flows refer to simmetrical spools.

POST-COMPENSATED SECTION

Spool type	flow rates (l/min)									
	5	10	15	25	35	50	65	80	100	
W001C	•	•	•	•	•	•	•	•	•	
W002C	•	•	•	•	•	•	•	•	•	
W102C				•		•			•	
W012C	•	•						•		

PRE-COMPENSATED SECTION

Spool type	flow rates (l/min)			
	15	25	40	65
W001C	•	•	•	•
W002C	•	•	•	•

Classification spool example

W001C - 2525

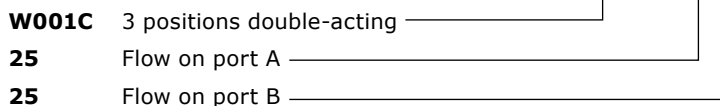

NOTE:

- not simmetric spools (such as 1025, 6535...) are available on request; for availability we suggest to contact our Sales department.
- rated flows are defined for 14 bar ΔP (as per KV inlet arrangement); for different ΔP values on variable pump systems, refer to diagram on page 12 (Post compensated spool flow with variable displacement pumps) or page 13 (Pre compensated spool flow with variable displacement pumps).
- Regenerative spools and spools with restricted service ports are available on request. Please contact our Sales department for more information.
- W012 spool needs a special machining on the valve body and a special detent kit.

Spool actuation classification for manual control

code	description	dimensions	configuration
H001	Lever actuation (only with manual and hydraulic section body)		
H004	Without lever actuation (only with manual and hydraulic section body)		

Joystick control spool actuation

The configuration of joystick control interests always two working sections with relative four ports:

A1 – B1 – A2 - B2.

For convention:

- section 1 is the first invested from the flow of the oil: it depends from the right or left inlet of the control valve
- Port A = spool action side
- Port B = spool return action side

The position of the fulcrum is identified by a code and stands in four configurations as shown in the following table:

Fulcrum / Inlet side	fulcrum - 1 st section	fulcrum - 2 nd section
Right inlet	H009	H010
Left inlet	H011	H012

code	description	configuration	code	description	configuration
H009	Right side inlet fulcrum on 1 st section (compulsory code for second section: H120) (only with manual and hydraulic section body)		H011	Left side inlet fulcrum on 1 st section (compulsory code for second section: H120) (only with manual and hydraulic section body)	
H010	Right side inlet fulcrum on 2 nd section (compulsory code for first section: H120) (only with manual and hydraulic section body)		H012	Left side inlet fulcrum on 2 nd section (compulsory code for first section: H120) (only with manual and hydraulic section body)	

Spools return action classification for manual control

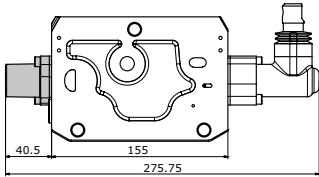
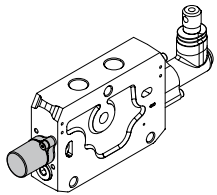
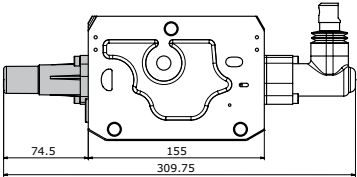
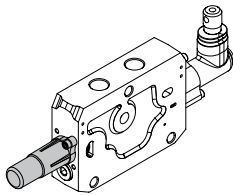
code	description	dimensions	configuration
F001A	3 position spring centered spool		
F001B	(only with manual and hydraulic section body)		
F002A	Detent in A and B (only with manual and hydraulic section body)		

Spool actuation classification for Hydraulic control

code	description	dimensions	configuration
H005A	Hydraulic actuation (pilot ports on the top) (only with manual and hydraulic section body)		
		Port pilot: 1/4" BSP - 9/16" UNF	
H005C	Hydraulic actuation (pilot ports on the sides) (only with manual and hydraulic section body)		
		Port pilot: 1/4" BSP - 9/16" UNF	
H005L	Hydraulic actuation with stroke limiter (only with manual and hydraulic section body)		
		Port pilot: 1/4" BSP - 9/16" UNF	
H403	Lever actuation + hydraulic actuation		
		Port pilot: 1/4" BSP - 9/16" UNF	
H428	lever + hydraulic actuation with electrohydraulic arrangement		
		Port pilot: 1/4" BSP - 9/16" UNF	
H429	Without lever + hydraulic actuation with electrohydraulic arrangement		
		Port pilot: 1/4" BSP - 9/16" UNF	

NOTE:
 Leave out the spool return action code when choosing hydraulic control.
 Recommended control curve for HC Remote Control: A01 for standard spool, A07 for float spool

Spool actuation classification for electrohydraulic control

code	description	dimensions	configuration
H404	Lever actuation + electrohydraulic actuation (12 vdc)		
H405	Lever actuation + electrohydraulic actuation (24 vdc)		
H404L	Lever actuation + electrohydraulic actuation with stroke limiter (12 vdc)		
H405L	Lever actuation + electrohydraulic actuation with stroke limiter (24 vdc)		
H407	Without lever + electrohydraulic actuation (12 vdc)		
H408	Without lever + electrohydraulic actuation (24 vdc)		
H424	lever + hydraulic actuation electrohydraulic actuation (12 vdc)		
H425	lever + hydraulic actuation electrohydraulic actuation (24 vdc)		
H426	Without lever + hydraulic actuation electrohydraulic actuation (12 vdc)		
H427	Without lever + hydraulic actuation electrohydraulic actuation (24 vdc)		

NOTE:
 Leave out the spool return action code when choosing electrohydraulic control.
 External drainage recommended (see page 32).

PROPORTIONAL ELECTROHYDRAULIC SPECIFICATIONS		
Feeding reducing pressure (bar)	35	
Supply voltage (Vdc)	12	24
Coil resistance R_{20} (Ω)	4,7	20,8
ON-OFF control current (mA)	2500	1150
Proportional control current (mA)	600 - 1300	300 - 650
PWM frequency suggested (Hz)	70 - 90	
Connector	AMP Junior Power Timer	

NOTE: mating connector for AMP Junior Power Timer can be ordered separately with code 413000223 (including 2 m wire).
 Different connector available on request.

Spools return action with hall effect Linear Position Sensor HLPS2

HLPS is a Hall effect sensor based device used in conjunction with spool position transducer kits available for HC-EX38. HC-HLPS is based on a state of the art programmable Hall effect sensor device; after the final assembly of the valve a computer assisted calibration procedure is performed that compensates for mechanical inaccuracies and uncertainties allowing to attain high accuracy and linearity in spool position detection. Spool position is output as an analog voltage signal in the 0.5 - 4.5V range. The unit works in 12V and 24V environments and is protected against load-dump and other major electrical faults. Fault signalling is carried out through the output signal. HLPS with the companion mechanical kit is therefore applicable in close loop feedback control applications and whenever determining spool position reliably is, as in safety functions, a major concern.



code	description	dimensions	configuration
F0470	Spool position indicator for manual control (only with manual section body)		
H404S	Spool position indicator for electrohydraulic actuation (12 vdc)		
H405S	Spool position indicator for electrohydraulic actuation (24 vdc)		

Technical specifications

Electrical	
Operating voltage	6 - 30 Vdc
Max current consumption	20.5 mA
Output	
Output voltage spanning	0.5 - 4.5 Vdc
Quiescent voltage	2.5 Vdc
Output current	-1 - +1 mA
Minimum output load resistance	4.5 kOhm
Overall accuracy	± 2.5%
Resolution	12 bit
Fault signalling levels	4.8V < Vout < 0.2 Vdc
Protections	short circuit protection, reverse, battery protection, thermal shutdown, overvoltage, undervoltage, load-dump > 60 Vdc/m
EM Immunity	
Mechanical, Environmental	
Operating temperature	-40 / +85 °C
Ingress Protection Rating	IP 65
Dimensions	28 x 18 x 23 mm (L x W x H)
Connections	
I/O	DIN 43650-C male
PIN 1	Vout
PIN 2	Vcc
PIN 3	OV
PIN 4	Chassis (connected to valve body)
Applied Standards	
Immunity for industrial environments	EN 61000-6-2
Emission standard for residential commercial and light-industrial environments	EN 61000-6-3
EMC - Agricultural and forestry machines	EN 14982
EMC - Earth-moving machinery	ISO 13766

NOTE: mating connector for DIN 43650-C can be ordered separately with code 487200314

Work section arrangement

HC-EX38 has been conceived as a post compensated flow sharing valve, but completely interchangeable pre compensated sections are also available. Pre compensated section can be freely mixed with post compensated ones. When using a pre compensated section between post compensated, priority is established for this section; if the system reaches flow saturation condition, all post compensated sections will reduce proportionally their delivered flows, while the pre compensated will keep a constant delivered flow. This function is particularly appreciated on applications where the loss of the speed for a specific function must be avoided when other functions are simultaneously activated. Following pages are showing ordering code for pre and post compensated section in their standard version and in combination with some specific applicable devices.

POST-COMPENSATED section standard

code	schema for manual control	schema for electrohydraulic control	configuration	description
RC1 G04				POST COMPENSATED section Arranged for auxiliary valves
RC1 U04				
RC2 G04				POST COMPENSATED section Not arranged for auxiliary valves
RC2 U04				

PRE-COMPENSATED section standard

code	schema for manual control	schema for electrohydraulic control	configuration	description
RL1 G04				PRE COMPENSATED section Arranged for auxiliary valves
RL1 U04				
RL2 G04				PRE COMPENSATED section Not arranged for auxiliary valves
RL2 U04				

Work section arrangement

POST-COMPENSATED section with local LS relief valve

Another feature not commonly found in flow sharing systems is the possibility to have a Load Sensing relief valve on individual sections. The purpose to use a local LS relief instead of a standard port shock relief is to improve the efficiency of the system. When a standard port shock relief is used, the full flow across the relief will be directed to tank, if the pressure system exceeds the setting.

By using a local LS relief, only a very minimal part of oil will be directed to tank in the same condition, with great advantage for the system efficiency. Furthermore, by saving oil from going to tank, more oil will be available for simultaneous operations and this will improve the performance of the machine.

The pressure limitation generated by the local LS relief applies to both section ports, A and B.

The local pressure limitation works properly if the section is actuated alone or if the section is the most charged.

The local LS relief can be easily installed as a retrofit too.

code	schema for manual control	schema for electrohydraulic control	configuration	description
RCD1 G04				<p>POST COMPENSATED section with local Load Sensing relief valve</p> <p>Arranged for auxiliary valves</p>
RCD1 U04				
RCD2 G04				<p>POST COMPENSATED section with local Load Sensing relief valve</p> <p>Not arranged for auxiliary valves</p>
RCD2 U04				

NOTE:

LS relief valve works on both ports; setting for A and B ports is the same

LS relief valve in combination with H404, H405, H407, H408, H424, H425, H426, H427, H428, H429 requires left inlet assembly.

LS relief valve setting must be specified as follow: RCD1 G04 (120)

Work section arrangement

PRE-COMPENSATED section with local LS relief valve

The purpose to use a local LS relief instead of a standard port shock relief is to improve the efficiency of the system. When a standard port shock relief is used, the full flow across the relief will be directed to tank, if the pressure system exceeds the setting.

By using a local LS relief, only a very minimal part of oil will be directed to tank in the same condition, with great advantage for the system efficiency. Furthermore, by saving oil from going to tank, more oil will be available for simultaneous operations and this will improve the performance of the machine.

The pressure limitation generated by the local LS relief applies to both section ports, A and B.

A typical case showcasing the advantages offered by this design is the grab function in loading cranes, or any other feature requiring that applied pressure be maintained, without affecting the speed of other simultaneous movements.

The local LS relief can be easily installed as a retrofit too.

code	schema for manual control	schema for electrohydraulic control	configuration	description
RLD1 G04				<p>PRE COMPENSATED section with local LS relief valve</p> <p>Arranged for auxiliary valves</p>
RLD1 U04				
RLD2 G04				<p>PRE COMPENSATED section with local LS relief valve</p> <p>Not arranged for auxiliary valves</p>
RLD2 U04				

NOTE:

LS relief valve works on both ports; setting for A and B ports is the same.

LS relief valve in combination with H404, H405, H407, H408, H424, H425, H426, H427, H428, H429 requires right inlet assembly.

LS relief valve setting must be specified as follow: RLD1 G04 (120)

Work section arrangement

POST-COMPENSATED section with local Flow limiter

The local compensator of a section can be equipped with a special knob which can be operated to adjust the maximum flow delivered by the section concerned.

This device acts by limiting the working flow of the local compensator and is working properly when a single section is operated.

This feature is highly appreciated because it ensures a certain degree of operating flexibility especially for those machines which must be equipped with different accessories (tractors and farming applications in general being a typical example).

The flow control device can be easily installed as a retrofit kit too.

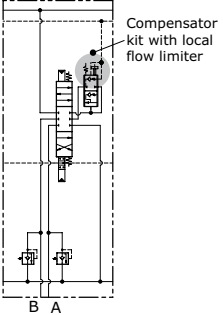
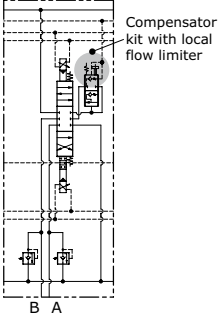
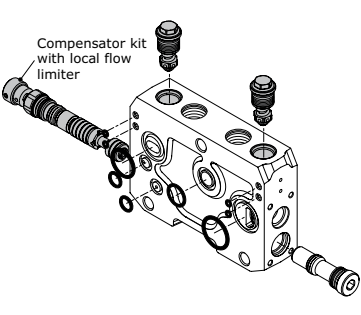
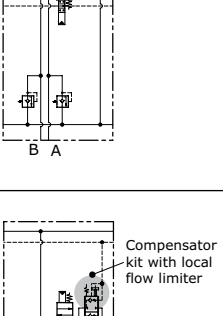
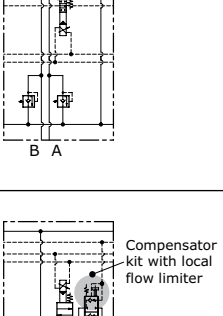
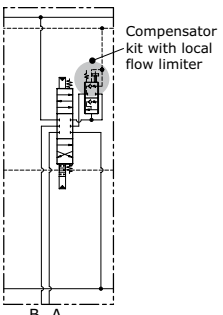
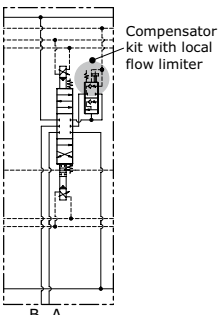
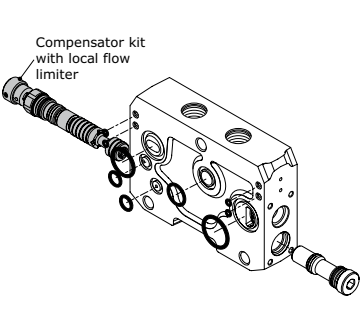
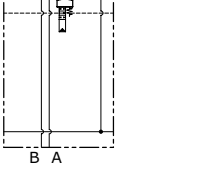
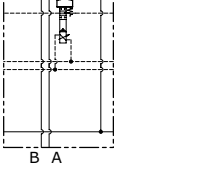



code	schema for manual control	schema for electrohydraulic control	configuration	description
RCE1 G04				POST COMPENSATED section with local flow limiter arranged for auxiliary valves
RCE1 U04				
RCE2 G04				POST COMPENSATED section with local flow limiter Not arranged for auxiliary valves
RCE2 U04				



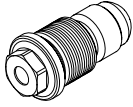

NOTE:

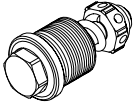
Local flow limiter in combination with H404, H405, H407, H408, H424, H425, H426, H427, H428, H429 requires right inlet assembly.

Auxiliary valve identification

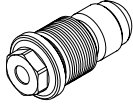
Valve setting is defined at 10 l/min flow. Look at Auxiliary valves diagram on page 14 to evaluate setting at actual flow.

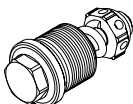
code	description	schema	configuration	setting range (bar)	
02TF PA	Fixed setting Anticavitation valve (port A)				
03TF PA	Fixed setting combined valve (port A)			A	40 / 350
05TF PA	Fixed setting Prearrangement for auxiliary valve (port A)				

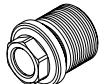
code	description	schema	configuration	setting range (bar)	
02TF PB	Fixed setting Anticavitation valve (port B)				
03TF PB	Fixed setting combined valve (port B)			A	40 / 350
05TF PB	Fixed setting Prearrangement for auxiliary valve (port B)				

Auxiliary valve - Setting range

Sections designed to house auxiliary valve option require double choice on work ports A and B.

Always indicate setting value when using fixed setting combined valve:

03TF PA (120) = setting

Auxiliary valves are not adjustable: factory settings are available from 40 to 350 bar with 10 bar steps

OUTLET SECTION (END PLATE)

There are two main types of End Plate:

- **Manual and Hydraulic control version:** to be used when no electrohydraulic controls are present in the valve: this plate is simply collecting the LS signal drain that can be connected to tank internally or externally without significant differences

- **Electrohydraulic version:** to be used when at least one section in the valve has electrohydraulic control: this plate is collecting LS signal and electrohydraulic controls drain and is providing electrohydraulic control feeding by means of a pressure reducing valve

IMPORTANT:

when electrohydraulic controls are present, the external drain to the tank, without any other additional pressure drop, is highly recommended to avoid control system damages and poor control properties.

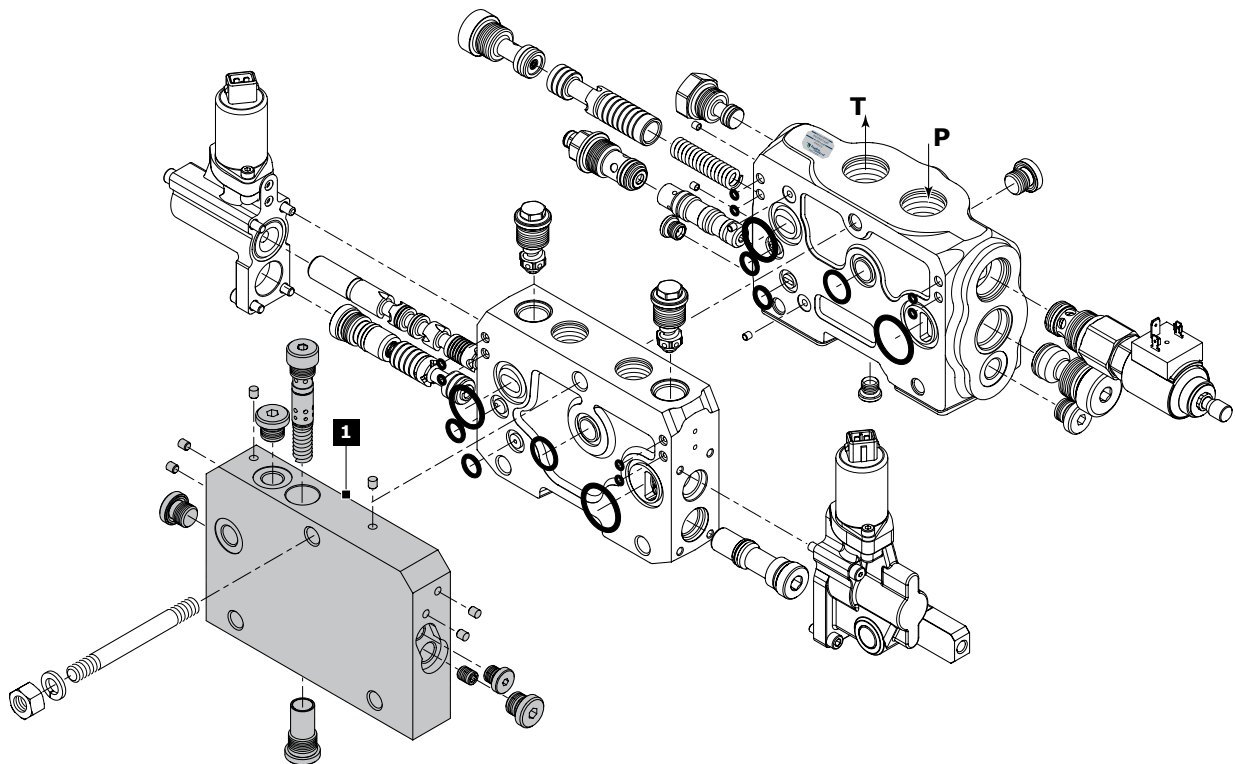
Order example**KZ20EH****1. KZ20EH** Plate type**1. OUTLET SECTION (END PLATE):****pg. 32**

KZ10I End plate without RDP internal drain (only for manual and hydraulic control)

KZ10E End plate without RDP external drain (only for manual and hydraulic control)

KZ20EC End plate with RDP external drain (only for electrohydraulic control)

KZ20EH End plate with RDP external-side drain (only for electrohydraulic control)

NOTE:

we recommend to keep the T line for the electrohydraulic cartridges separate from the T line of the valve.

End plate for manual and hydraulic control

code	schema	configuration	description
KZ10I			End plate without RDP internal drain to be used with: H001-H004 H005A-H005C-H005L H403-H428-H429
KZ10E			End plate without RDP external drain to be used with: H001-H004 H005A-H005C-H005L H403-H428-H429

End plate for electrohydraulic control

code	schema	configuration	description
KZ20EC			End plate with RDP external drain to be used with: H404-H405-H407 H408-H424-H425-H426
KZ20EH			End plate with RDP external-side drain to be used with: H404-H405-H407 H408-H424-H425-H426

NOTE: Left inlet assembled valve with lever kit H403, H404, H405, H424, H425, H428 on the last section accepts only KZ20EH and KZ10I end plate.

Parallel connection of several valves

Thanks to an interesting construction design, it is possible to obtain parallel connection of several control valves without that the flow sharing function efficiency and simultaneity of movement being affected. The circuit available either for fixed or variable pump, requires P, T and LS signal connection according to the following diagram. This solution is especially successful in the loading crane or forestry crane industries for single pump circuits.

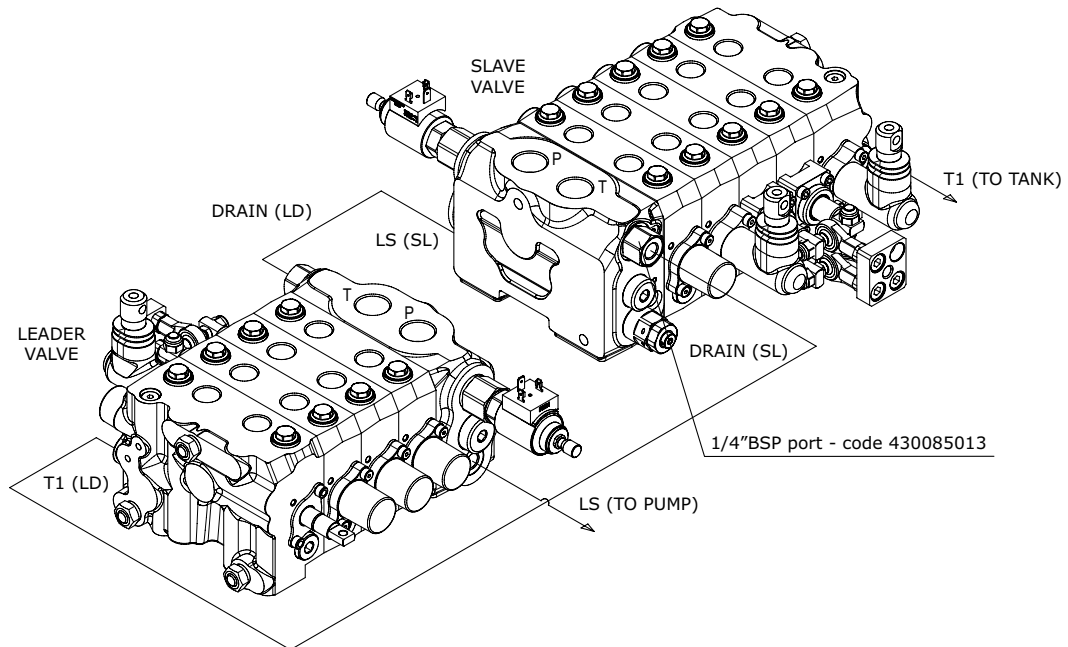

High pressure carry over function

The Carry Over function is yet another unique option offered by the EX family. In fixed pump circuits, two control valves connected in succession can be used to ensure flow through both valves' inlet compensators. This special design is obtained by using a special inlet cover on the first valve. This circuit is ideally suitable for trailer-equipped machines, since the connection between the two control valves is achieved by simply using one pipe for P and one pipe for T (no additional LS signal connections are necessary).

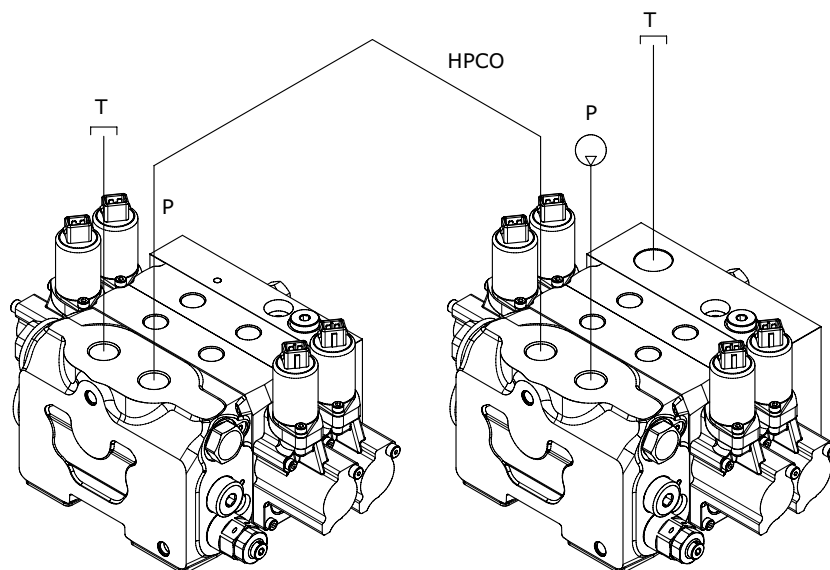

EX38 SPARE PARTS LIST

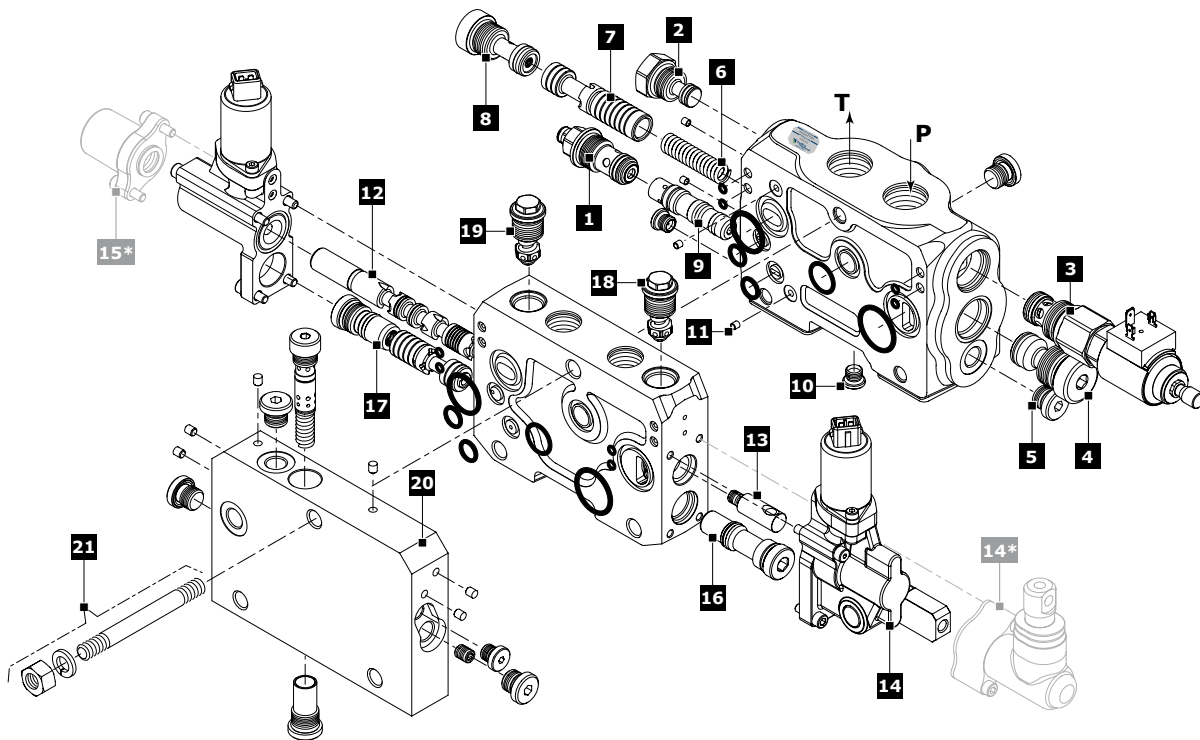

Rif.	Description	Order code	Q.ty	Type	Note	
1	LS pressure relief valve (*)	80741	1		Setting: 100 bar	
		80742	1		Setting: 200 bar	
		80743	1		Setting: 300 bar	
		430085034	1			
2	LS relief plug	430059003	1			
		915040410	1			
		915040411	1			
3	LS plug	430059003	1			
		915040410	1			
		915040411	1			
4	Full flow pilot operated pressure relief valve (*)	35824	1		Setting: 100 bar	
		26698	1		Setting: 250 bar	
		80208	1		Setting: 400 bar	
		430175001	1			
		915045501	1			
		915045502	1			
4	Plug kit	430085001	1			
5	Plug kit 1/4"G DIN 3852 E	430000017	2		(q.ty = 1 for JV version)	
6	Inlet compensator spring	421803249	1			
7	Assembly inlet Compensator Spool	433085001	1		only for KV	
		433085002	1		only for JV	
8	Inlet compensator plug kit	430085004	1		only for KV	
		430085012	1		only for JV	
9	Valve	430085005	1		only for KV	
		430085046	1		only for JV	
10	Plug kit G(PF) 1/8"	320062003	2			
11	Plug MB 700-040	413180005	4			
POST - COMPENSATED SECTION						
Rif.	Description	Order code	Q.ty	Type	Note	
12	3 positions double-acting spool	421293030	1	W001C-0505	spool 5 l/min	
		421293035	1	W001C-1010	spool 10 l/min	
		421293019	1	W001C-1515	spool 15 l/min	
		421293040	1	W001C-2525	spool 25 l/min	
		421293015	1	W001C-3535	spool 40 l/min	
		421293010	1	W001C-5050	spool 50 l/min	
		421293020	1	W001C-6565	spool 65 l/min	
		421293013	1	W001C-8080	spool 80 l/min	
		421293032	1	W001C-100100	spool 100 l/min	
		3 positions double-acting partly open to tank	421293049	1	W002C-1010	spool 10 l/min
			421293051	1	W002C-1515	spool 15 l/min
			421293043	1	W002C-2525	spool 25 l/min
421293117	1		W002C-3535	spool 35 l/min		
421293034	1		W002C-5050	spool 50 l/min		

Rif.	Description	Order code	Q.ty	Type	Note
	3 positions double-acting partly open to tank	421293039	1	W002C-6565	spool 65 l/min
		421293062	1	W002C-100100	spool 100 l/min
	4 positions double-acting with float in the 4 th pos.	421293086	1	W012C-0505	spool 5 l/min
		421293093	1	W012C-1010	spool 10 l/min
		421293092	1	W012C-8080	spool 80 l/min
13	Spool end kit	422501217	1		
		422501205	1		only for H001
		422501153	1		only for H004
14	Lever and hydraulic front kit	320585011	1	H403	BSP version
	Lever and hydraulic front kit	320585013	1	H403	UNF version
	Lever and electrohydraulic front kit (12 V)	322093001	1	H404	
	Lever and electrohydraulic front kit + stroke limiter (12 V)	322093035	1	H404L	
	Lever and electrohydraulic front kit (24 V)	322093003	1	H405	
	Lever and electrohydraulic front kit + stroke limiter (24 V)	322093037	1	H405L	
	Without lever and electrohydraulic front kit (12 V)	322093008	1	H407	
	Without lever and electrohydraulic front kit (24 V)	322093009	1	H408	
	Lever + hydraulic + electrohydraulic front kit (12 V)	322093010	1	H424	BSP version
	Lever + hydraulic + electrohydraulic front kit (12 V)	322093011	1	H424	UNF version
	Lever + hydraulic + electrohydraulic front kit (24 V)	322093017	1	H425	BSP version
	Lever + hydraulic + electrohydraulic front kit (24 V)	322093012	1	H425	UNF version
	Without lever + hydraulic + electrohydraulic front kit (12 V)	322093027	1	H426	BSP version
	Without lever + hydraulic + electrohydraulic front kit (12 V)	322093025	1	H426	UNF version
	Without lever + hydraulic + electrohydraulic front kit (24 V)	322093028	1	H427	BSP version
	Without lever + hydraulic + electrohydraulic front kit (24 V)	322093026	1	H427	UNF version
15	Lever + hydraulic rear kit	320585012	1	H403	BSP version
	Lever + hydraulic rear kit	320585014	1	H403	UNF version
	Lever + electrohydraulic rear kit (12 V)	322093002	1	H404	
	Lever + electrohydraulic rear kit + stroke limiter (12 V)	322093036	1	H404L	
	Lever + electrohydraulic rear kit (24 V)	322093004	1	H405	
	Lever + electrohydraulic rear kit + stroke limiter (24 V)	322093038	1	H405L	
	Without lever + electrohydraulic rear kit (12 V)	322093002	1	H407	
	Without lever + electrohydraulic rear kit (24 V)	322093004	1	H408	
	Lever + hydraulic + electrohydraulic rear kit (12 V)	322093018	1	H424	BSP version
	Lever + hydraulic + electrohydraulic rear kit (12 V)	322093013	1	H424	UNF version
	Lever + hydraulic + electrohydraulic rear kit (24 V)	322093019	1	H425	BSP version
	Lever + hydraulic + electrohydraulic rear kit (24 V)	322093014	1	H425	UNF version
	Without lever + hydraulic + electrohydraulic rear kit (12 V)	322093019	1	H426	BSP version
	Without lever + hydraulic + electrohydraulic rear kit (12 V)	322093014	1	H426	UNF version
	Without lever + hydraulic + electrohydraulic rear kit (24 V)	322093019	1	H427	BSP version
	Without lever + hydraulic + electrohydraulic rear kit (24 V)	322093014	1	H427	UNF version
14*	Lever actuation kit	320366001	1	H001	Manual version
	Without lever actuation kit	320366003	1	H004	Manual version
	Hydraulic front kit (upper ports)	320585007	1	H005A	Hydraulic version
	Hydraulic frontkit (side ports)	320585009	1	H005C	Hydraulic version
	Hydraulic front kit (with stroke limiter)	320585003	1	H005L	Hydraulic version
15*	Hydraulic kit (upper)	320585008	1	H005A	Hydraulic version
	Hydraulic rear kit (side)	320585010	1	H005C	Hydraulic version
	Hydraulic rear kit (with stroke limiter)	320585004	1	H005L	Hydraulic version
	3 position spring centered spool	320793001	1	F001A	only with H001 or H004
	Detent in A and B	320893001	1	F002A	only with H001 or H004
	Spool position indicator kit	320093001	1	F0470	only with H001 or H004
16	Plug kit	430085006	1		only for body RC or RCE
	L.S. relief valve kit	915008501	1		only with body RCD
		915008502	1		85/200 bar
		915008503	1		205/350 bar
17	Section compensator kit	320085001	1		only for body RC or RCD
	Section compensator kit with stroke limiter	320085006	1		only with body RCE
PRE - COMPENSATED SECTION					
Rif.	Description	Order code	Q.ty	Type	Note
12	3 positions double-acting spool	421293048	1	W001C-1515	spool 15 l/min
		421293063	1	W001C-2525	spool 25 l/min
		421293064	1	W001C-4040	spool 40 l/min
	3 positions double-acting partly open to tank	421293091	1	W002C-1515	spool 15 l/min
		421293082	1	W002C-2525	spool 25 l/min
		421293081	1	W002C-4040	spool 40 l/min
		421293080	1	W002C-6565	spool 65 l/min
13	Spool end kit	430085026	1		
		430085037	1		only for H001
		430085045	1		only for H004
14	Lever and electrohydraulic front kit (24 V)	322093034	1	H405	
15	Lever + electrohydraulic rear kit (24 V)	322093033	1	H405	
14*	Hydraulic front kit (upper ports)	320585019	1	H005A	Hydraulic version
	Hydraulic frontkit (side ports)	320585025	1	H005C	Hydraulic version
	Hydraulic front kit (with stroke limiter)	320585015	1	H005L	Hydraulic version

Rif.	Description	Order code	Q.ty	Type	Note
15*	Hydraulic kit (upper)	320585020	1	H005A	Hydraulic version
	Hydraulic rear kit (side)	320585026	1	H005C	Hydraulic version
	Hydraulic rear kit (with stroke limiter)	320585016	1	H005L	Hydraulic version
16	Plug kit	430085029	1		only with body RL
	L.S. relief valve kit	915008504	1	50/170 bar	only with body RLD
		915008505	1	175/420 bar	only with body RLD
17	Section compensator kit	320085008	1		only for body RL or RLD
18	Anticavitation valve on port A	915089001	1	02TF PA	
	Combined valve fixed setting on port A (*)	915870100	1	03TF PA	Fixed setting: 100 bar
		915870150	1	03TF PA	Fixed setting: 150 bar
		915870200	1	03TF PA	Fixed setting: 200 bar
		915870250	1	03TF PA	Fixed setting: 250 bar
		915870300	1	03TF PA	Fixed setting: 300 bar
		915870350	1	03TF PA	Fixed setting: 350 bar
	Prearrangement for auxiliary valve on port A	430490001	1	05TF PA	
19	Anticavitation valve on port B	915089001	1	02TF PB	
	Combined valve fixed setting on port B (*)	915870100	1	03TF PB	Fixed setting: 100 bar
		915870150	1	03TF PB	Fixed setting: 150 bar
		915870200	1	03TF PB	Fixed setting: 200 bar
		915870250	1	03TF PB	Fixed setting: 250 bar
		915870300	1	03TF PB	Fixed setting: 300 bar
		915870350	1	03TF PB	Fixed setting: 350 bar
	Prearrangement for auxiliary valve on port B	430490001	1	05TF PB	
20	End plate without RDP (internal drain)	320093101	1	KZ10I	BSP version
	End plate without RDP (internal drain)	320093103	1	KZ10I	UNF version
	End plate without RDP (external drain)	320093102	1	KZ10E	BSP version
	End plate without RDP (external drain)	320093104	1	KZ10E	UNF version
	End plate with RDP (external drain)	320093123	1	KZ20EC	BSP version
	End plate with RDP (external drain)	320093127	1	KZ20EC	UNF version
	End plate with RDP (external-side drain)	320093124	1	KZ20EH	BSP version
	End plate with RDP (external-side drain)	320093128	1	KZ20EH	UNF version
21	Tie rod kit EX38/1	300193022	3		
	Tie rod kit EX38/2	300193015	3		
	Tie rod kit EX38/3	300193016	3		
	Tie rod kit EX38/4	300193017	3		
	Tie rod kit EX38/5	300193010	3		
	Tie rod kit EX38/6	300193011	3		
	Tie rod kit EX38/7	300193012	3		
	Tie rod kit EX38/8	300193013	3		
	Tie rod kit EX38/9	300193014	3		
	Tie rod kit EX38/10	300193018	3		

Note

(*) = for different settings please contact our Sales Dpt.

(**) = electric dump valve coil can be ordered separately as spare part: (see drawing)
 Ordering code Coil 12 vdc: 413171235
 Ordering code Coil 24 vdc: 413172432

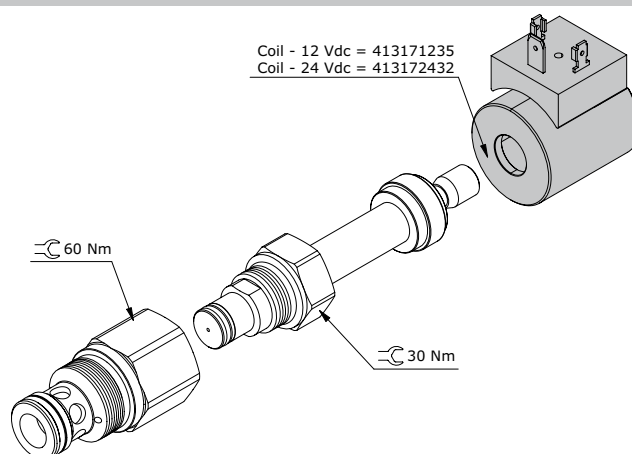

Gasket kits

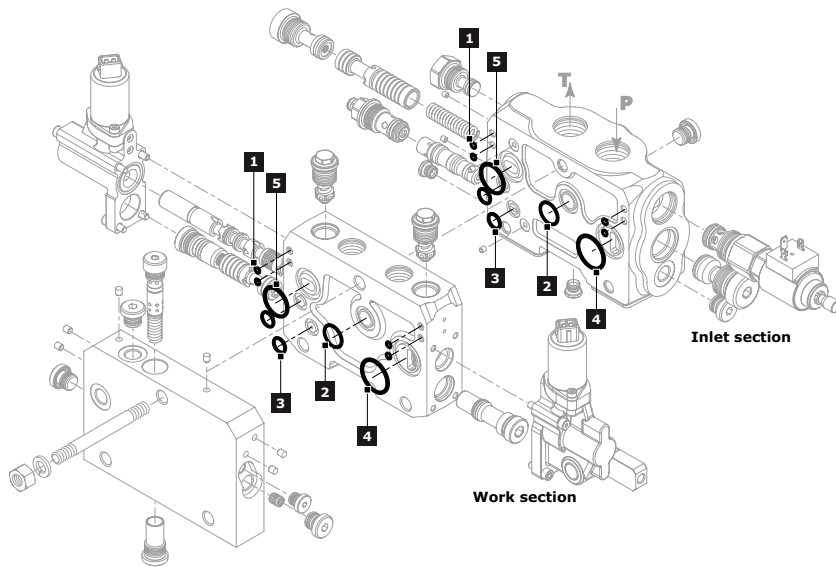

INLET AND WORK SECTION			
Rif.	order code	Description	Q.ty
1	412020118	O.R.90SH (N27OR050)	4
2	412020302	O.R.90SH (3-908)	1
3	412020303	O.R.90SH (6-532)	2
4	412020605	O.R.90SH (2-120)	1
5	412020610	O.R.90SH (2-118)	1
Complete Gasket kit: order code - 350993001			

Trasformation kits

Transformation on the inlet section from open center to closed center is possible by ordering the complete kit code: **320093007 (transformation kit from KV to JV)**

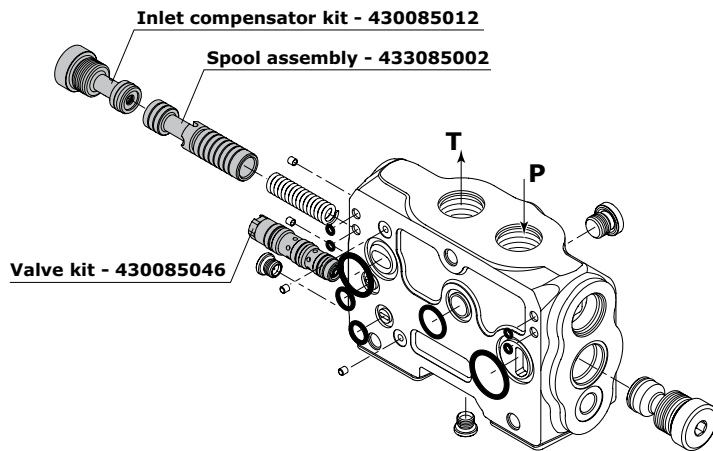

OPEN CENTER CONFIGURATION (JV) VARIABLE PUMP		
order code	Description	Q.ty
430085012	Inlet compensator kit	1
430085046	Valve kit	1
433085002	Spool assembly	1
Complete transformation kit: order code - 320093007		

Transformation on the inlet section from closed center to open center is possible by ordering the complete kit code: **320093008 (transformation kit from JV to KV)**

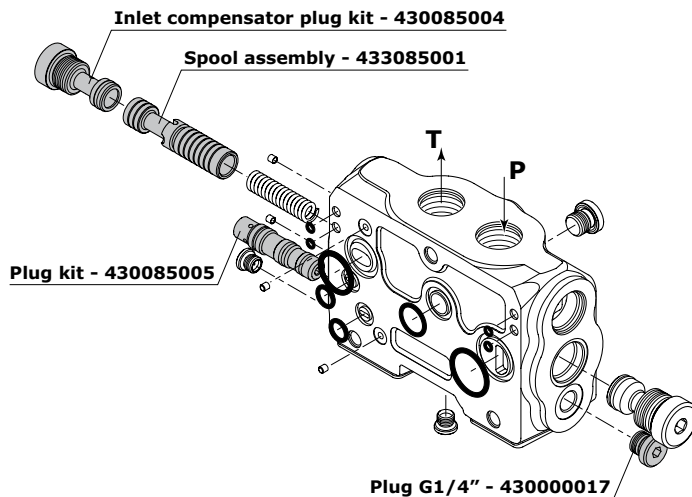

OPEN CENTER CONFIGURATION (KV) FIXED PUMP		
order code	Description	Q.ty
430000017	Plug G1/4"	1
430085004	Inlet compensator plug kit	1
430085005	Plug kit	1
433085001	Spool assembly	1
Complete transformation kit: order code - 320093008		

INSTALLATION AND MAINTENANCE

Guidelines

- Mount the control valve securely to a flat surface (recommended 3 point fixing); at the time do not use a hammer to positioning by hitting.
- When handling the control valve, be careful not hold the pilot cover or return spring cap of the spool or accessory valves such as main relief valves and anti-shock relief valves.
- Clean piping materials sufficiently before use.
- Make sure to prevent the port openings from being entered with dust or foreign matters.
- Tighten the port connectors surely with the recommended fastening torques.
- Do not direct the jet of a pressure washing unit directly to the valve.

Fittings tightening torque (Nm)

thread type	port P	Port A - B	Port T
BSP (ISO - 228)	G 3/4	G 1/2	G 3/4
with rubber sealing (DIN 3869)	70	60	70
with copper or steel and rubber washer	70	60	70
UN-UNF (ISO - 725)	1"1/16 - 12 UNF	7/8" - 14 UNF	1"1/16 - 12 UNF
with O.R.	95	90	95

General clamping torque

The following table provides the main tightening torques of the distributor HC-EX38; are highlighted in 3 separate drawings depicting the inlet section, the working section and the outlet section.

Inlet Section

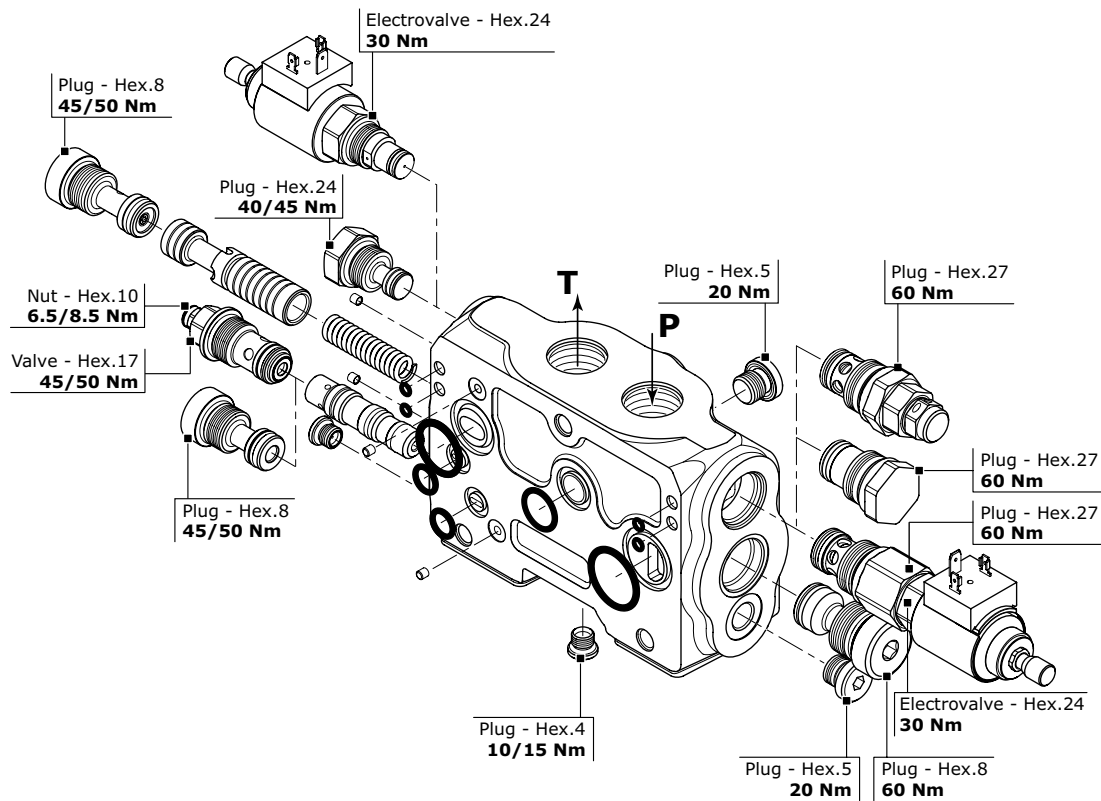

Work Section

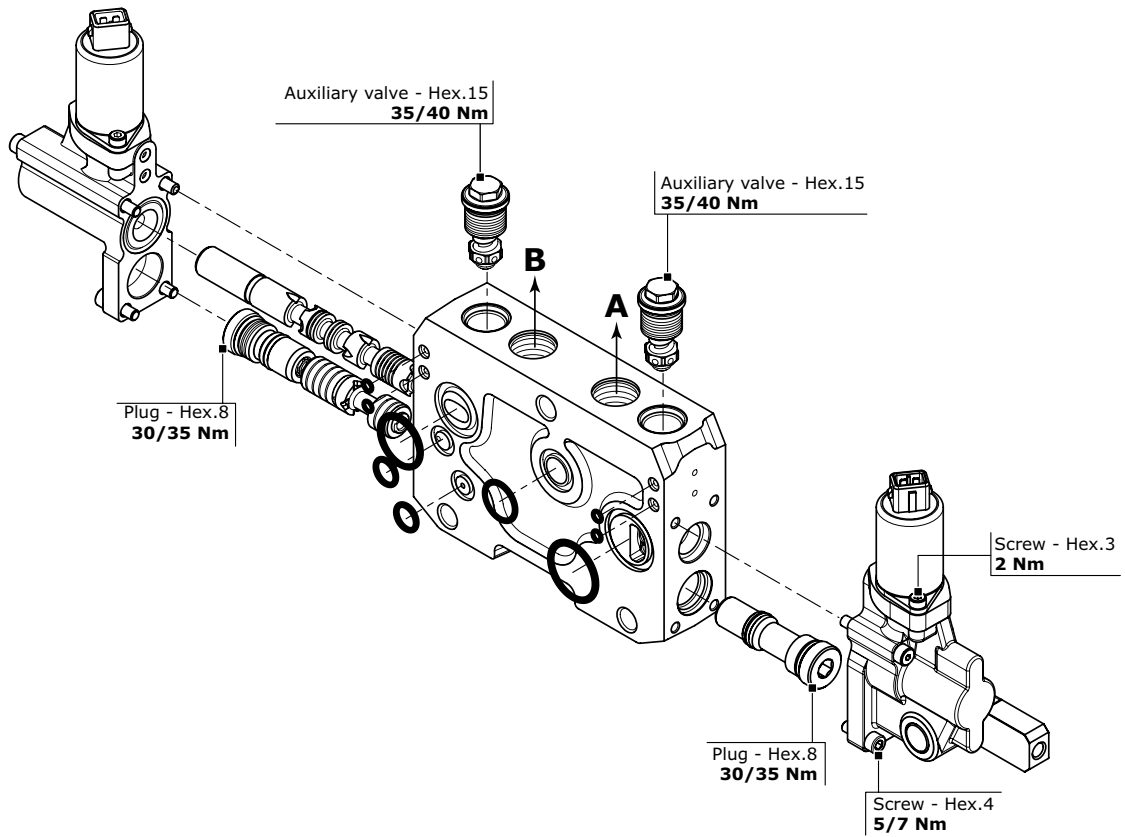

Outlet Section

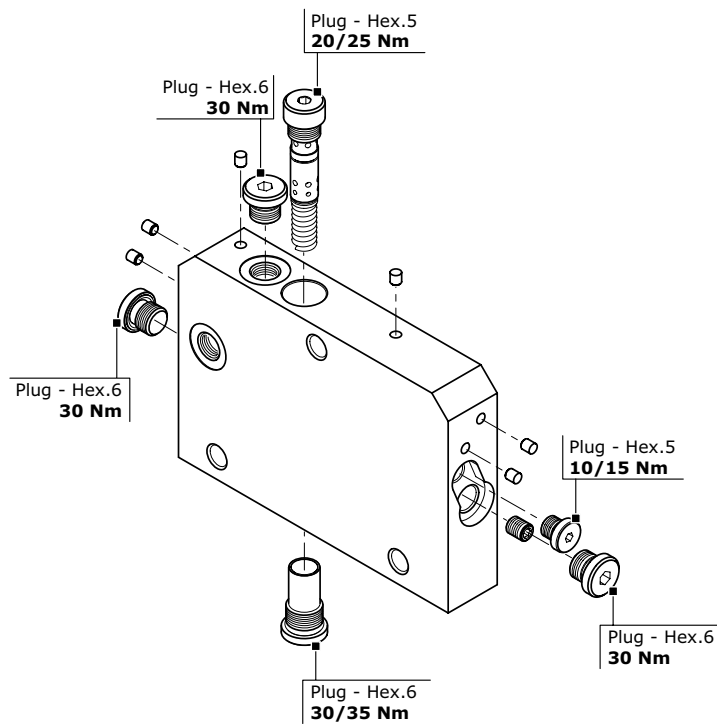

Dimensions - Thread codes

The connection ports size is indicated by an ordering code common for all Hydrocontrol products. Following table shows all available connections.

METRIC THREAD (ISO 9974-1)												
Type	M18x1,5	M22x1,5	M27x2									
Code	M01	M02	M03									

BSP THREAD (ISO 1179-1)												
Type	1/4"	3/8"	1/2"	3/4"	1"	1 1/4"	1 1/2"	2"				
Code	G02	G03	G04	G05	G06	G07	G08	G09				

UN / UNF THREAD (ISO 11926-1)							
Type	9/16" 18 UNF SAE6	3/4" 16 UNF SAE8	7/8" 14 UNF SAE10	1 1/16" 12 UNF SAE12	1 5/16" 12 UNF SAE16	1 5/8" 12 UNF SAE20	
Code	U02	U03	U04	U05	U06	U07	

Dimensions - SAE Flange codes

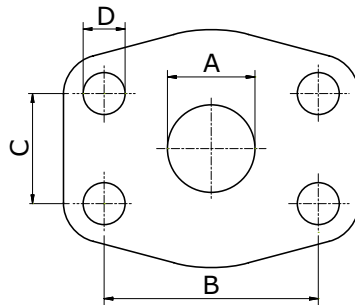

SAE / 3000 FLANGE (ISO 6162-1)												
Type	3/4" (MA)	3/4" (UNC)	1" (MA)	1" (UNC)	1 1/4" (MA)	1 1/4" (UNC)	1 1/2" (MA)	1 1/2" (UNC)	2" (MA)	2" (UNC)	3" (MA)	3" (UNC)
Code	S03	S04	S05	S06	S07	S08	S09	S10	S11	S12	S15	S16
A	19	19	25	25	32	32	38	38	51	51	76	76
B	47,6	47,6	52,4	52,4	58,7	58,7	69,9	69,9	77,8	77,8	106,4	106,4
C	22,3	22,3	26,2	26,2	30,2	30,2	35,7	35,7	42,9	42,9	61,9	61,9
D	M10	3/8-16	M10	3/8-16	M10	7/16-14	M12	1/2-13	M12	1/2-13	M16	5/8-11

SAE / 6000 FLANGE (ISO 6162-2)												
Type	3/4" (MA)	3/4" (UNC)	1" (MA)	1" (UNC)	1 1/4" (MA)	1 1/4" (UNC)	1 1/2" (MA)	1 1/2" (UNC)				
Code	S33	S34	S35	S36	S37	S38	S39	S40				
A	19	19	25	25	32	32	38	38				
B	50,8	50,8	57,2	57,2	66,6	66,6	79,3	79,3				
C	23,8	23,8	27,8	27,8	31,8	31,8	36,5	36,5				
D	M10	3/8-16	M12	7/16-14	M14	1/2-13	M16	5/8-11				

GENERAL CONDITIONS AND PATENTS

Product identification

All Hydrocontrol products have an identifying plate placed in specific position.



Serial number

Serial number:
It univocally identifies the physical valve: this provides an easy way to find all sales and production details.

Product code

Product code:
It is a number univocally identifying the configuration and pressure settings of a valve.

Introduction

These general conditions apply to all general supplies from Hydrocontrol s.p.a., after receiving orders from the Customer. Should commercial terms such as EXW, DDP, etc be mentioned, of course the Incoterms of the International Chamber of Commerce must be referred to, according to the test existing when the general supply conditions are agreed on.

Management of orders

No Customer's order is binding to Hydrocontrol s.p.a. if Hydrocontrol s.p.a. has not confirmed the order in writing. Hydrocontrol s.p.a. commits to supplying the orders in compliance with the order confirmation that has been issued. Any disagreement with the content of the order confirmation must be communicated in writing to Hydrocontrol s.p.a. within and no later than 5 days from the delivery of the order confirmation. The Customer commits to paying for the goods supplied by Hydrocontrol s.p.a., according to the prices indicated on the order confirmation.

Payment conditions

The Parties agree on the payment terms at the beginning of the supply. The terms will be indicated on the order confirmation. Should the Customer be late with the payments, Hydrocontrol S.p.a. will be entitled to require the payment of interests on arrears based on the exiting Prime Rate increased by 2%. Should there be any payment delay, Hydrocontrol s.p.a. will be entitled not to process the Customer's purchase order, even if it has already been confirmed.

Delivery and shipment

The goods are always supplied Ex Works, even when Hydrocontrol s.p.a. agrees with the Customer that the shipment, or a part of it, will be arranged by Hydrocontrol s.p.a. It is agreed that the Customer will bear the risk of goods deterioration or damaging from the moment the goods are handed by Hydrocontrol s.p.a. to the first carrier.

Product characteristics

Hydrocontrol s.p.a. commits to supplying good quality products, compliant with the technical specifications declared on the technical tables and on the catalogue. Hydrocontrol s.p.a, even without notice, at its own discretion, reserves the right to modify the products as necessary, without these changes altering the main characteristics of the products.

Claims

Any claims about defects on delivered products (just as an example: claims about the packaging, the number, the quantity or the external product characteristics) will have to be notified to Hydrocontrol s.p.a. in writing, within and no later than 7 days from reception of the goods, otherwise the claims will be considered as null and void. Occult defects (the defects of the goods that cannot be spotted with a careful control of the goods received by the Customer), will have to be notified in writing to Hydrocontrol s.p.a. within 7 days from the discovery of the defect, and anyhow no later than 12 months from the delivery of the goods, otherwise the claim will be considered as null and void. Even in case of claim or objection, the Customer will never be entitled to suspend or delay the payments to Hydrocontrol s.p.a. for the products subject to claim or objection nor for any other supply.

Warranty

Should the products supplied by Hydrocontrol not be compliant or have the required quality and should this defect be due to Hydrocontrol, Hydrocontrol s.p.a. commits, at its choice, to replace or repair the faulty products, as long as the defect or lack of compliance is notified to Hydrocontrol s.p.a. in writing, as specified at point 6, within and no later than 18 months from product delivery. On the products that have been fixed or replaced in accordance with what specified above, the above-mentioned warranty applies. The 12 month duration starts from the date of repair or replacement. In case of defects, lack of quality or in case of lack of compliance for the supplied products, with the exception of fraud or serious offence, Hydrocontrol s.p.a. only commits to repairing or replacing the faulty products, according to what specified above. This warranty replaces any other Supplier's warranty or liability established by the law. This warranty excludes any other liability contractual or extra-contractual by Hydrocontrol s.p.a. on the products supplied by Hydrocontrol (as a mere example: damage refund, loss of profit, product recall campaign, etc). Hydrocontrol s.p.a. has signed a product civil liability police, with a suitable maximum coverage.

Ownership retention

The products supplied by Hydrocontrol s.p.a. will be owned by the latter until Hydrocontrol receives the complete payment for the supplied goods.

Obligation confidentiality

Hydrocontrol s.p.a. commits to not disclosing the technical and commercial information it receives from the Customer, unless this information has already been publicly disclosed.

Patents

The Customer is not allowed to use the provided Products, or a part of them, their descriptions or drawings protected or not protected by Patent or registered trademark in order to design or make similar products, unless Hydrocontrol s.p.a. previously issues its written authorization. Should Hydrocontrol s.p.a. give its written authorization, all patents, trademarks, registered designs, copyrights and intellectual property rights related or connected to the Products provided by Hydrocontrol s.p.a. will stay Hydrocontrol's property. The Customer commits to respecting the highest confidentiality.

Applicable law and court of jurisdiction

Hydrocontrol s.p.a.'s supplies are regulated by these General Supply Conditions and, for anything not defined here, by the Italian law. Any controversy related, generated or connected to the supply of Products by Hydrocontrol s.p.a., where Hydrocontrol s.p.a. is involved, will be exclusively dealt with by the Court of Bologna.

**HEAD QUARTERS
Hydrocontrol SpA**

Via San Giovanni 481 . 40060 Osteria Grande
Castel S.Pietro Terme . Bologna - Italy
Phone +39.051.6959411 (15 linee)
Fax +39.051.946476
Phone sales Dep.: +39.051.6959447
Fax sales Dep.: +39.051.6958132
info@hydrocontrol-inc.com

**U.S.A.
Hydrocontrol Inc.**

1109 Technology Drive . Red Wing, MN 55066 U.S.A
Phone +1 (651) 212 6400 . Fax +1 (651) 212 6401
usa@hydrocontrol-inc-com

**GERMANY
Hydrocontrol GmbH**

Rudolf Diesel Str. 1 42477 Radevormwald
Deutschland
Phone +49 2195-931123 Fax +49 2195-931124
hans.ley@hydrocontrol-inc.de

**FRANCE
HC France SAS**

7, Rue des Entrepreneurs . Parc de la Vertonne
44122 Vertou . France
Phone +33 02-40332348 . Fax +33 02-28210034
hc-france@wandoo.fr

INDIA**HC Hydraulic Technologies (P) LTD**

A5 (B) Ngef Ancillary Indl. Estate
Whitefield Road . Mahadevpura (Po)
Bangalore . 560048
India
Phone +91 (080) 40454707
Fax +91 (080) 40454703
info@hydrocontrol-india.com

CHINA**HC China Sales and Production Facility**

Guangzhou Bushi Hydraulic Technology Ltd
Shangwei Shaheshe, Yuehu Village
Xiancun, Xintang Town . Zengcheng City
511335 Guangzhou . Guangdong Province
China
Phone +86 (021) 52380695
Fax +86 (021) 52380697
fareast@hydrocontrol-inc-com